

MIT Student Art Association Spring 2011

# Digital Photography

# Depth of Field



**Depth of Field**, in its most basic sense, is controlled by the size of the **aperture**.



# Aperture

Think of squinting.



*f/2*

# Aperture

Think of squinting.



*f/2.8*

# Aperture

Think of squinting.



*f/4*

# Aperture

Think of squinting.



*f/5.6*

# Aperture

Think of squinting.



*f/8*

# Aperture

Think of squinting.



*f/22*

**DoF:** two extremes



# **Narrow** Depth of Field

Large aperture, small f-number ( $f/1.8$ ).



Irving Penn

# **Wide** Depth of Field

Small aperture, large f-number ( $f/64$ ).



Ansel Adams





*f/1.4*

*1/60 sec*





*f/16*

*2.5 sec*

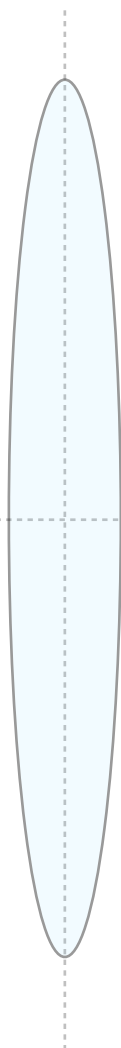

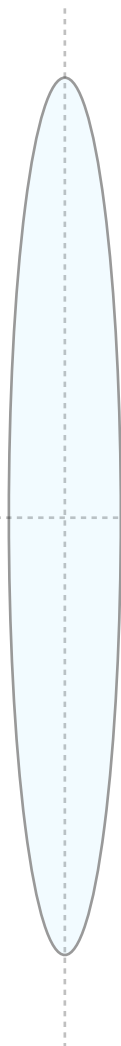



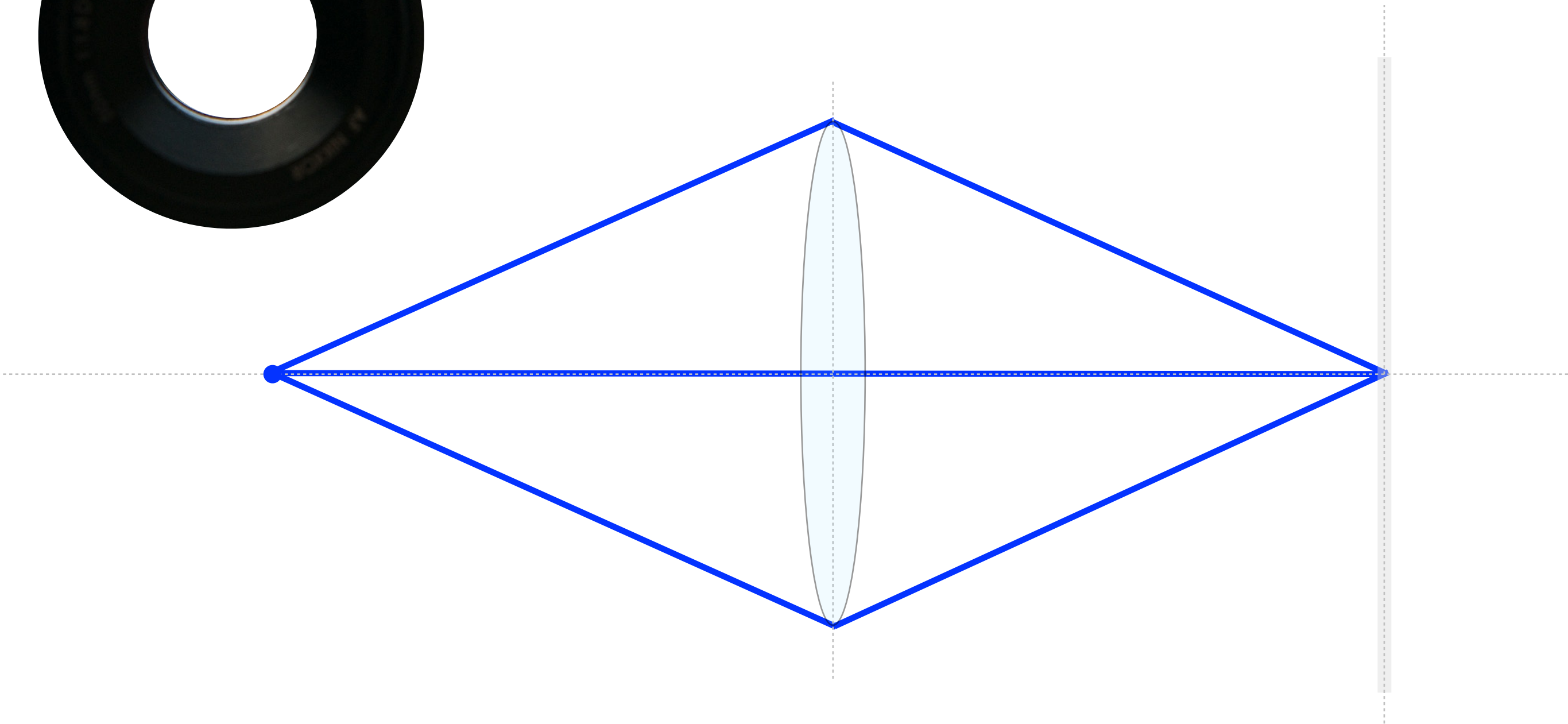



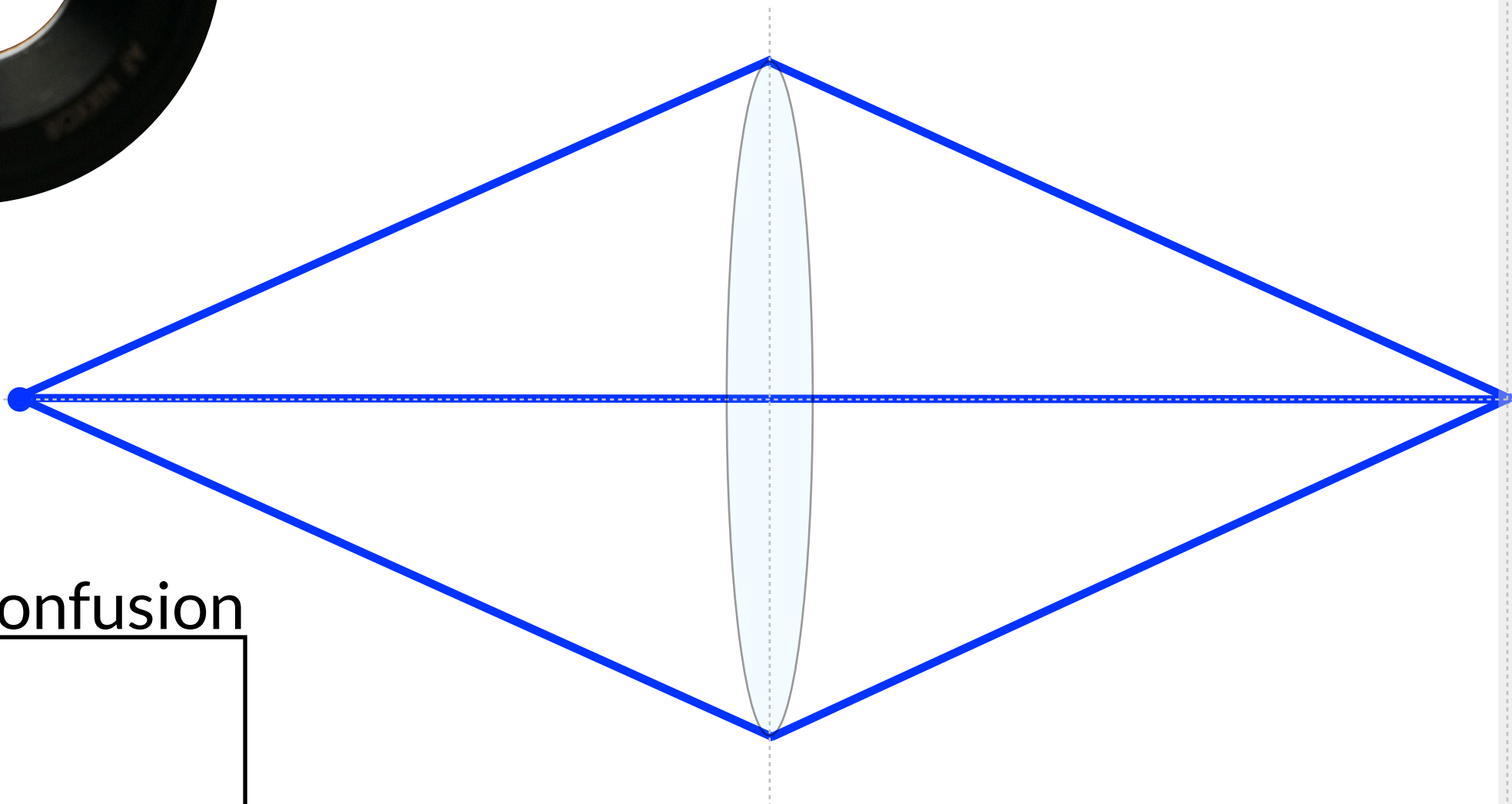

circle of confusion

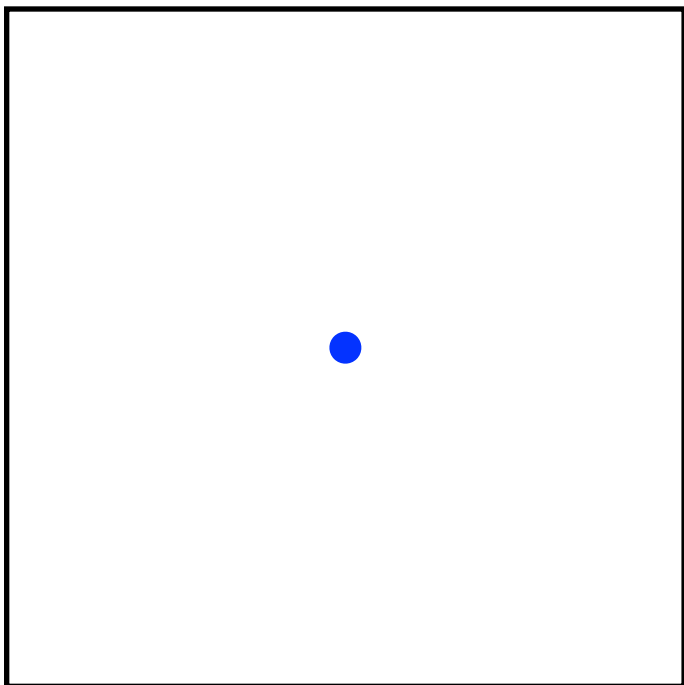

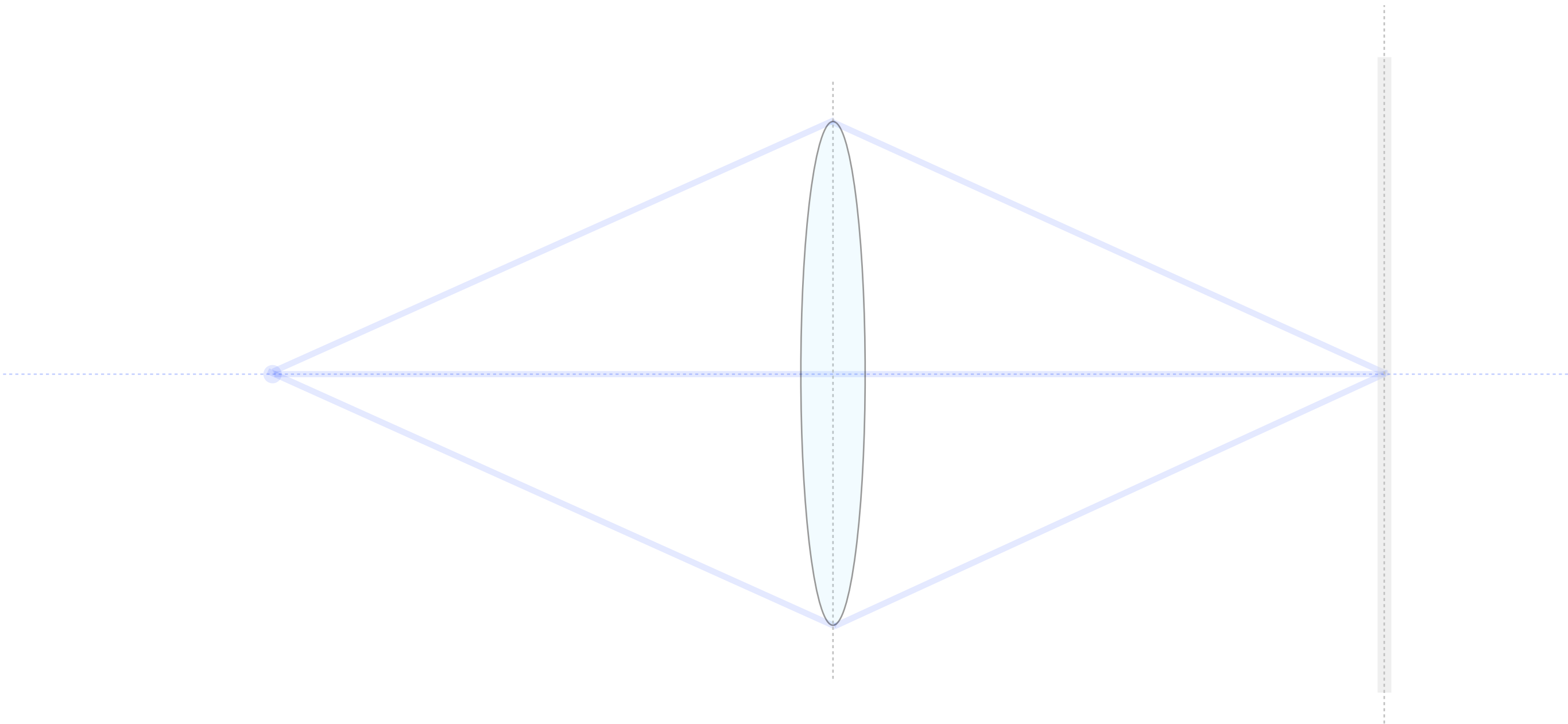

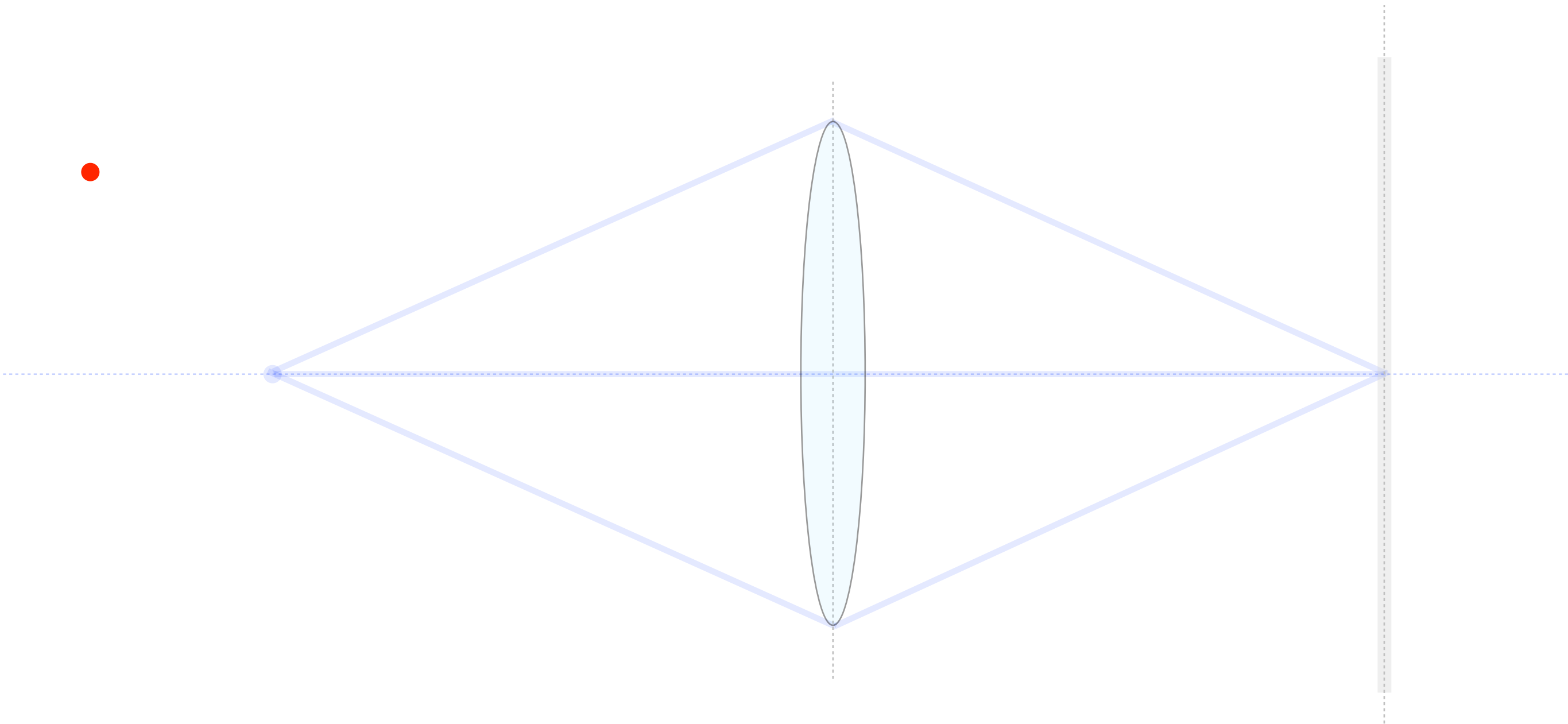

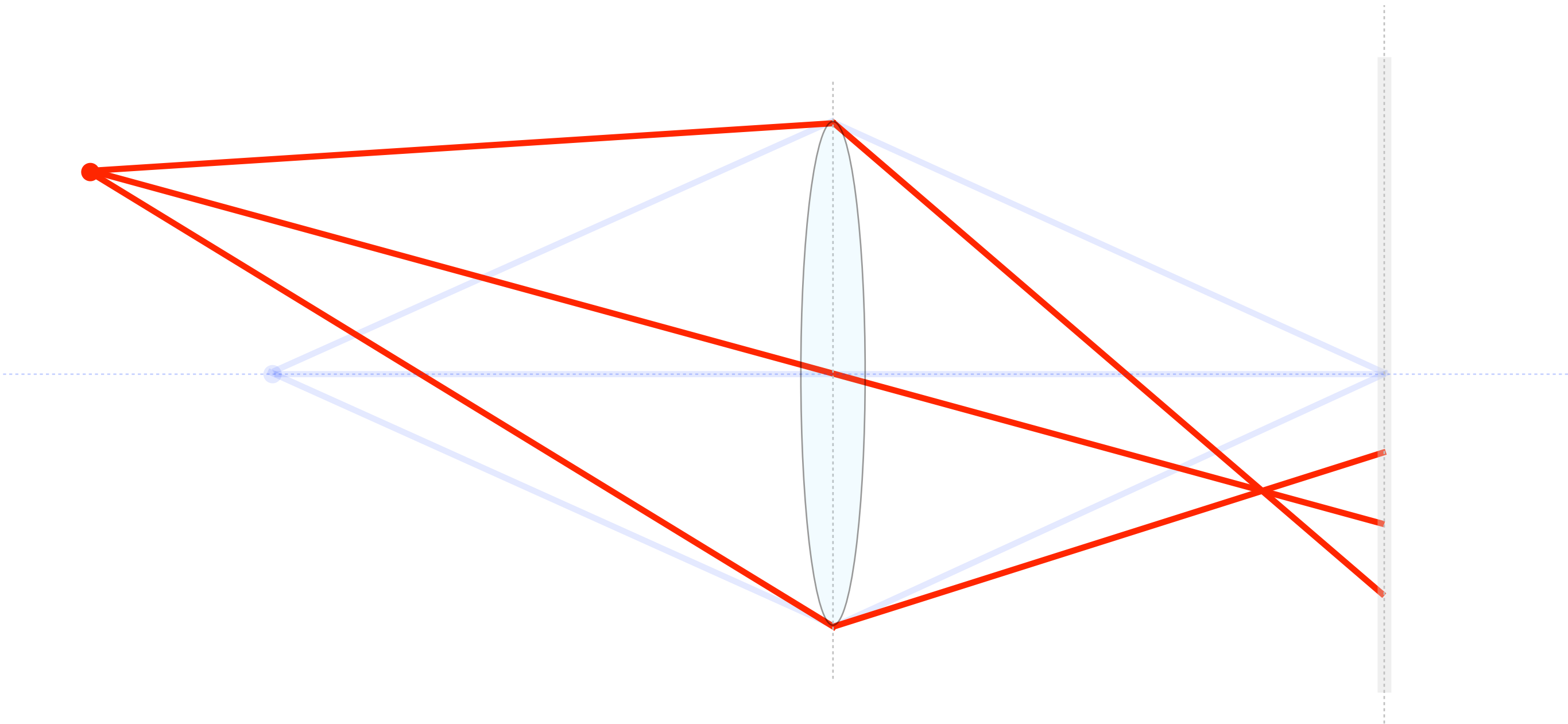

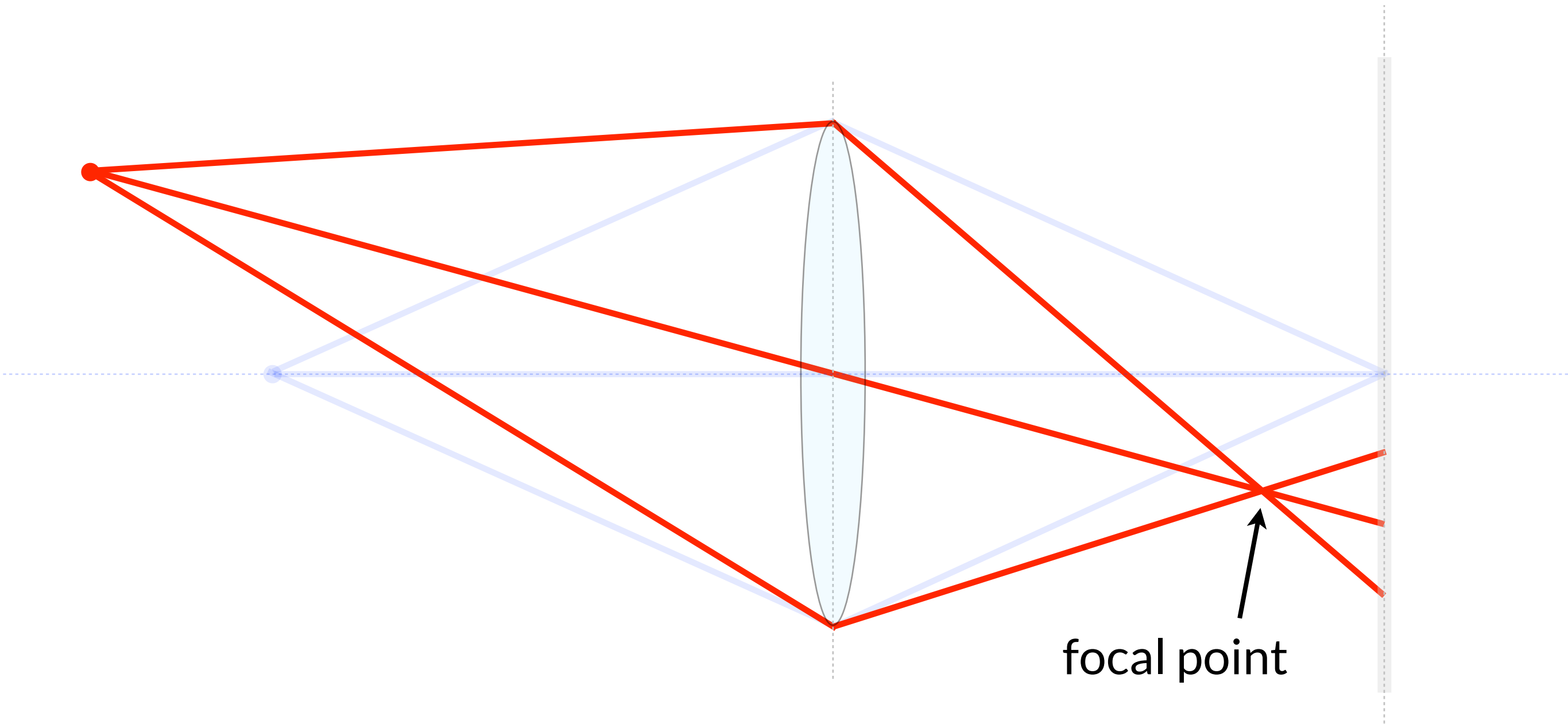

focal point

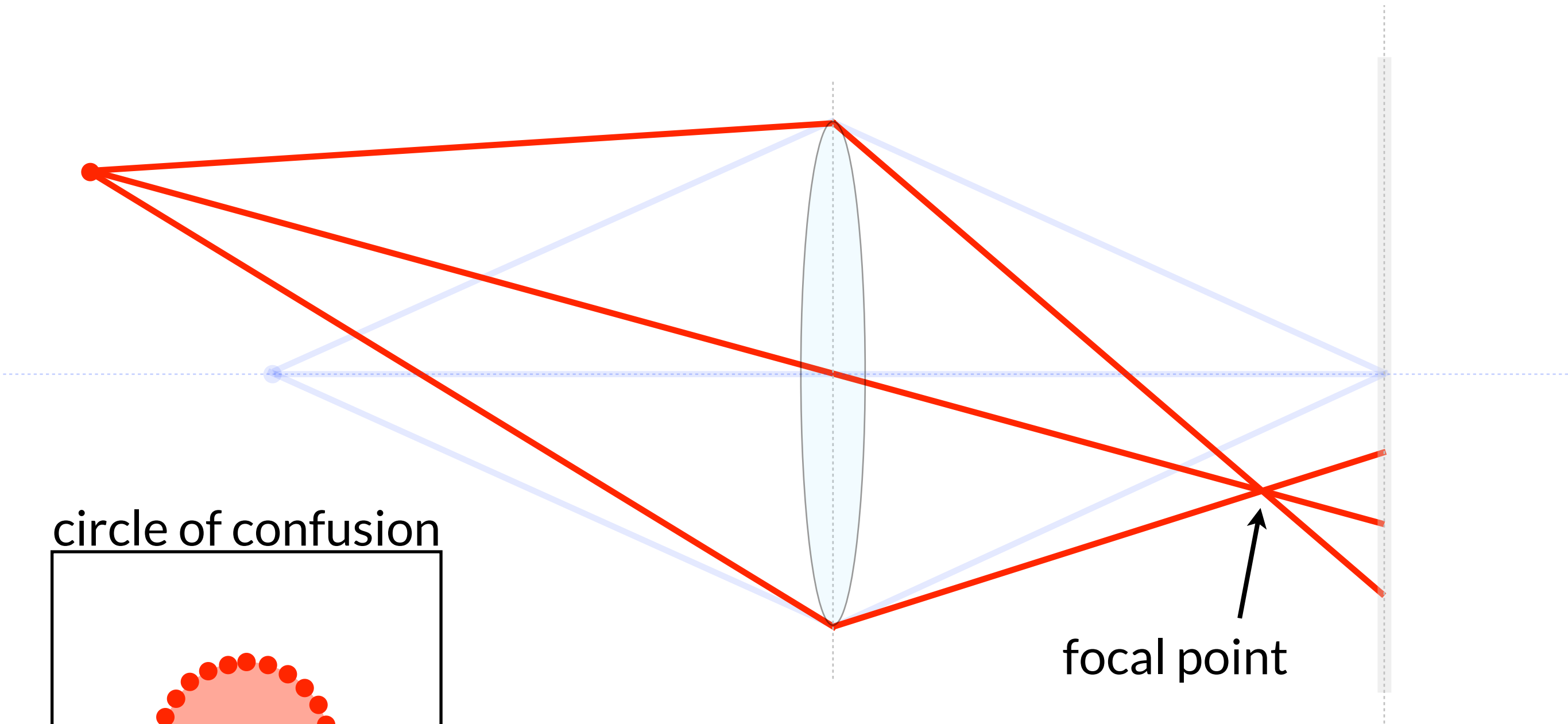

circle of confusion

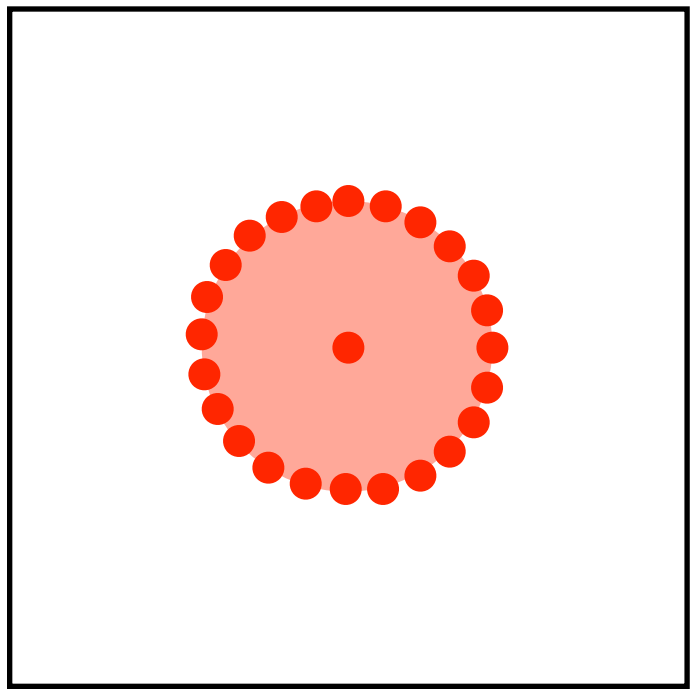

focal point

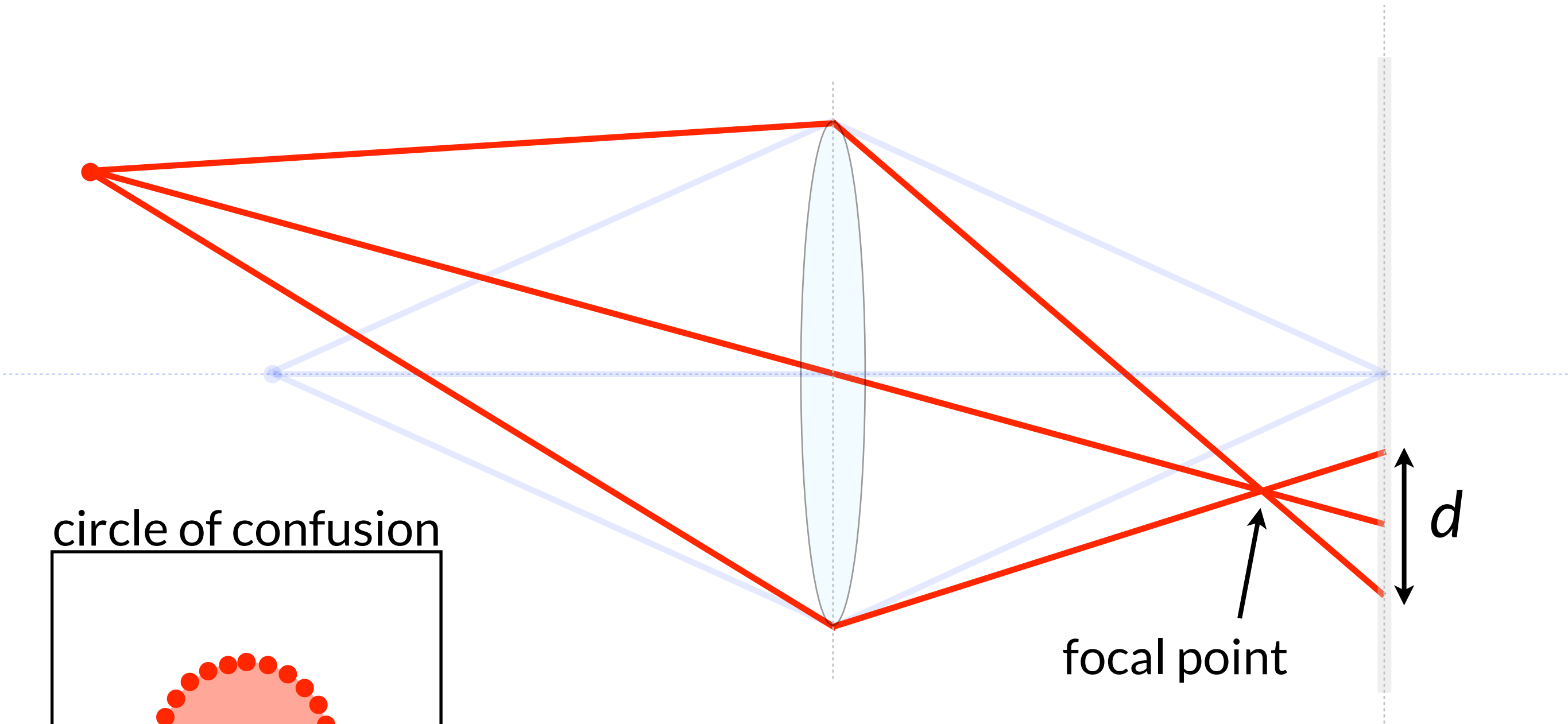

circle of confusion

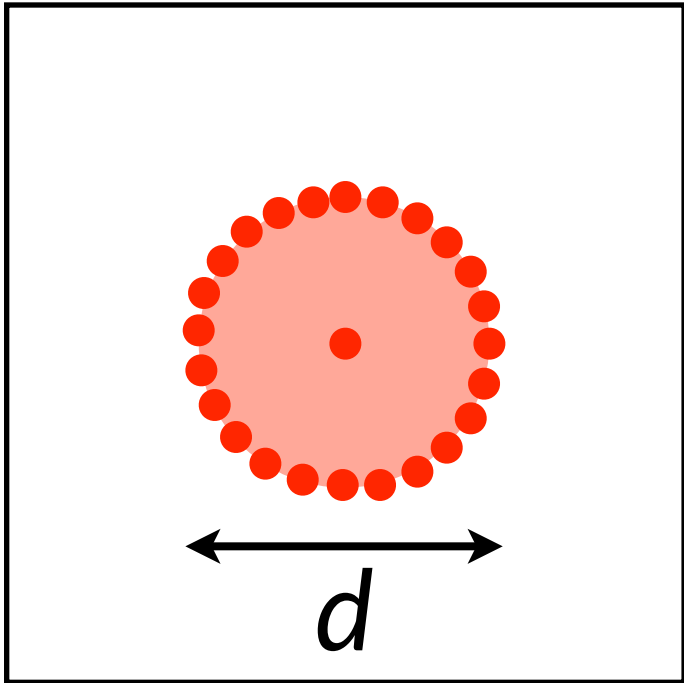

focal point

$d$

$d$



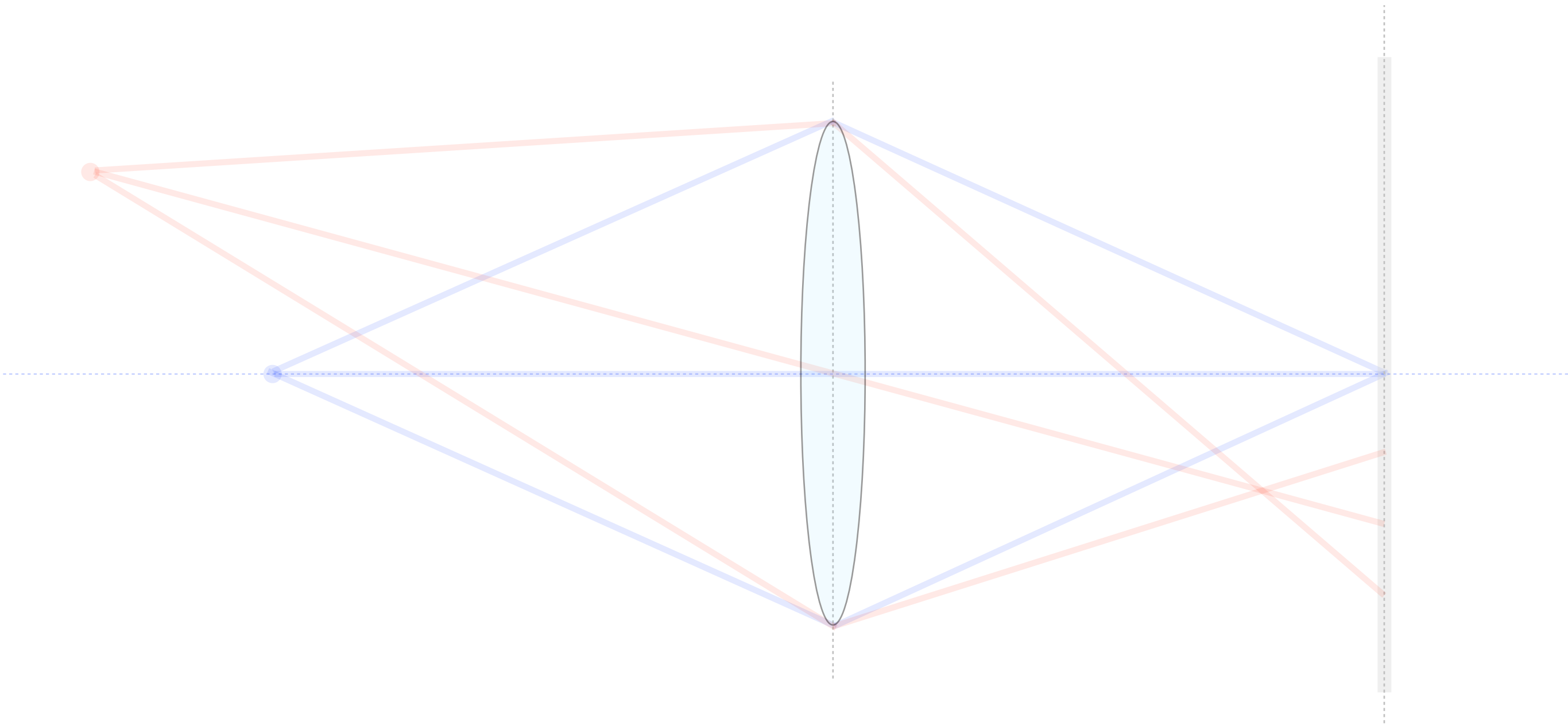

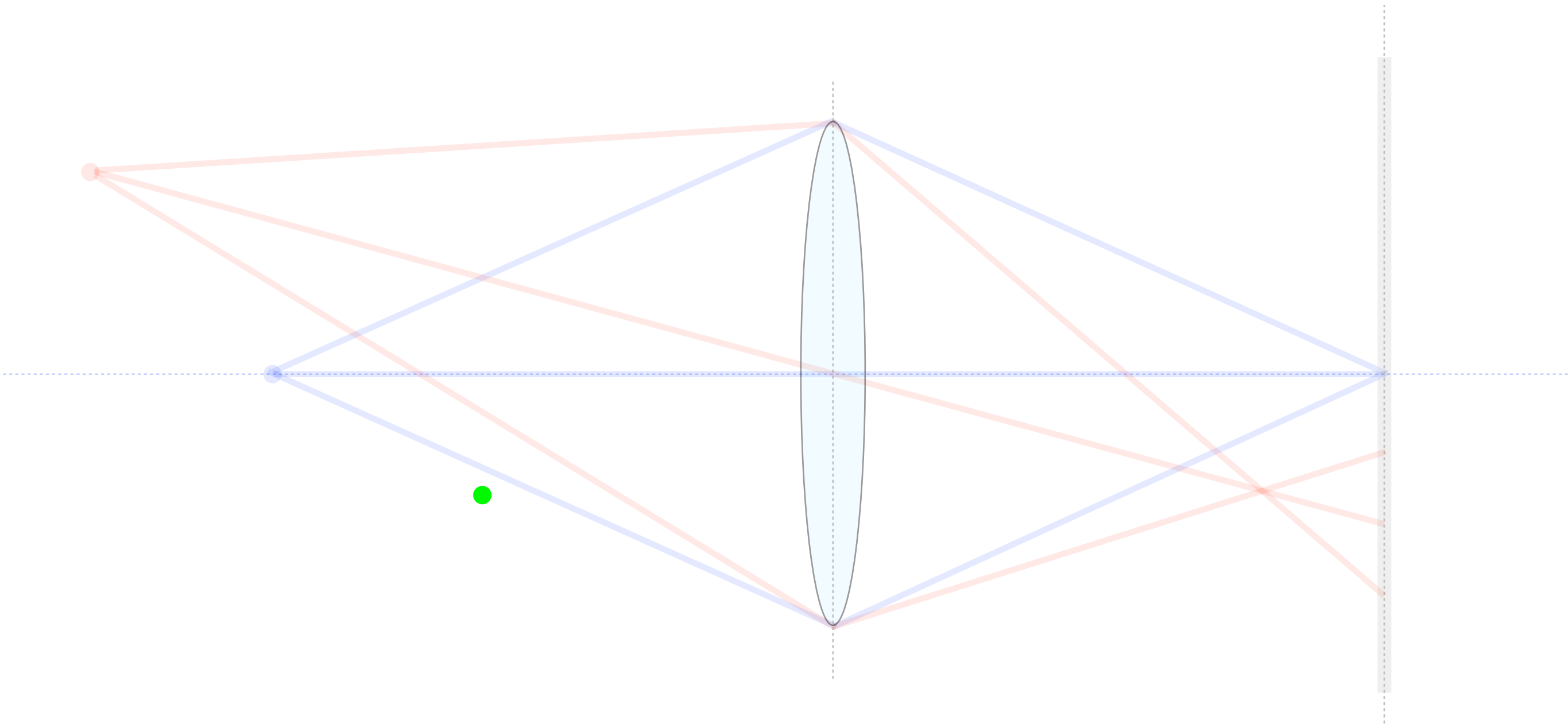

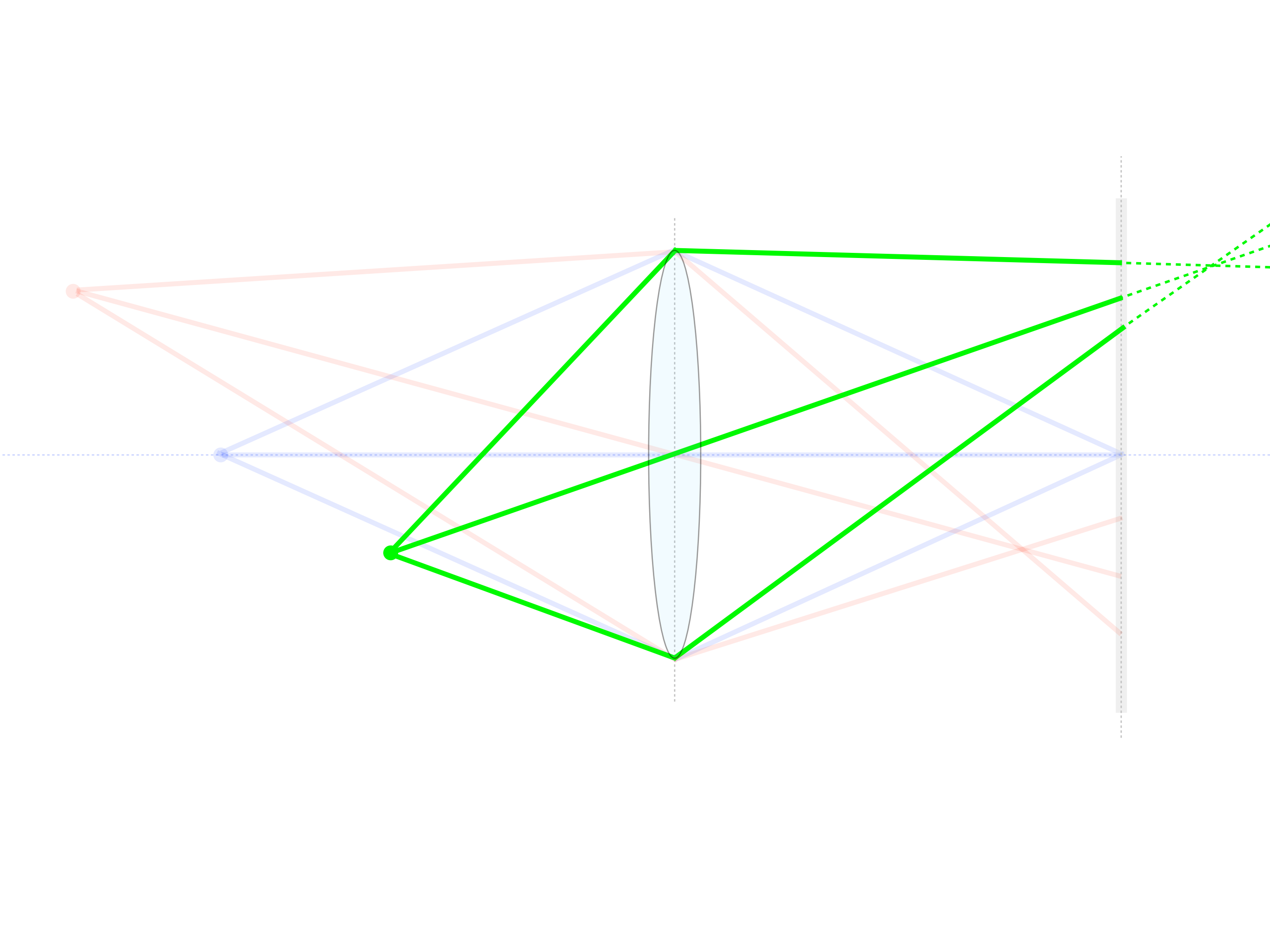

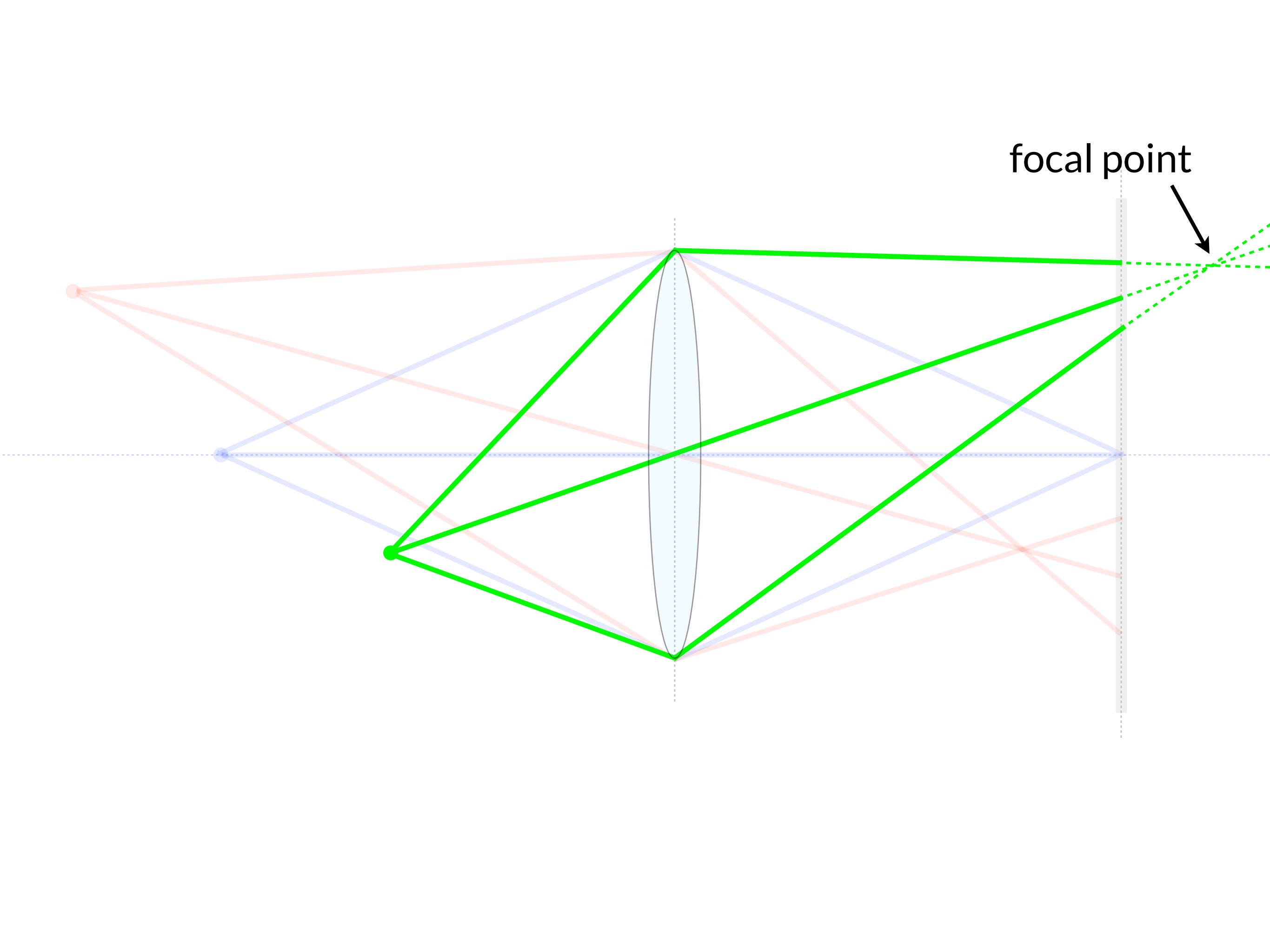

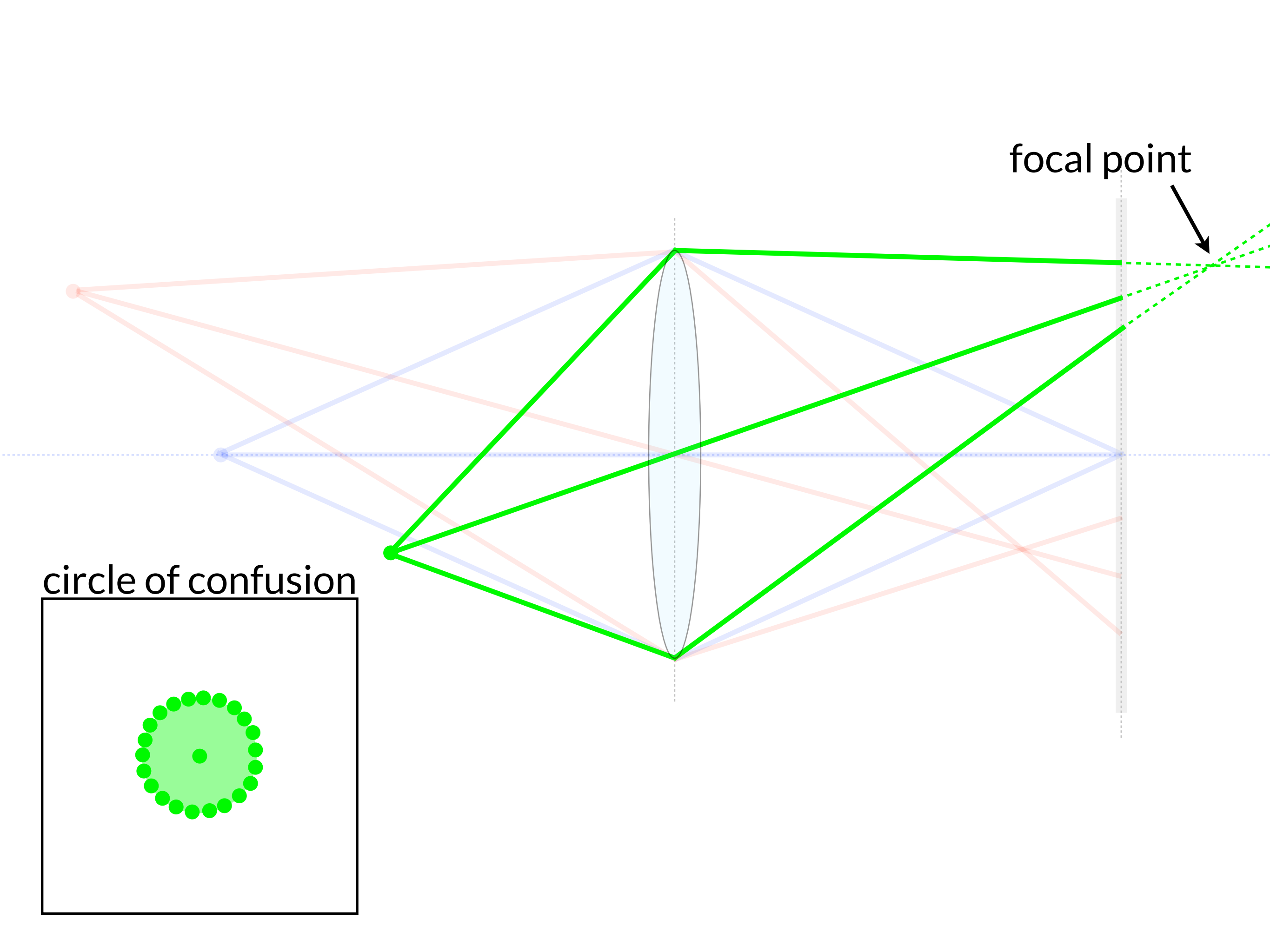

focal point

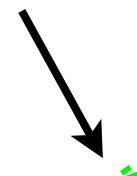

circle of confusion

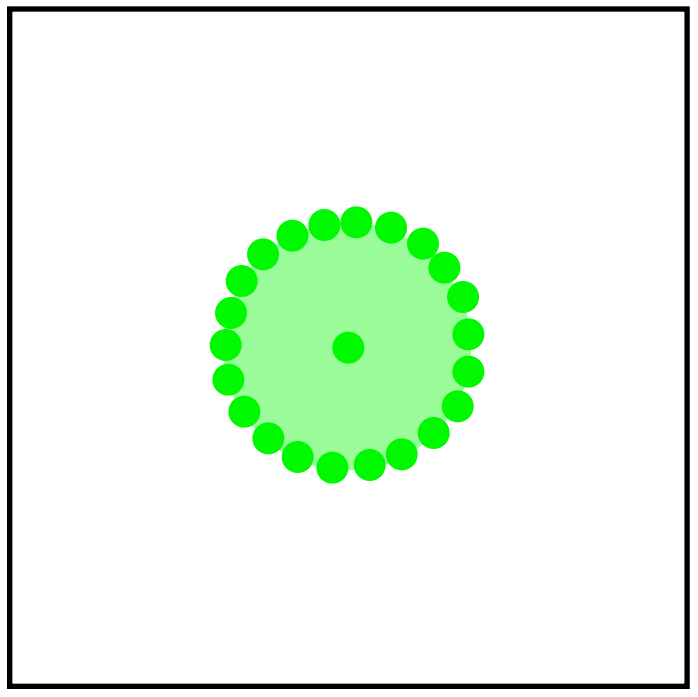

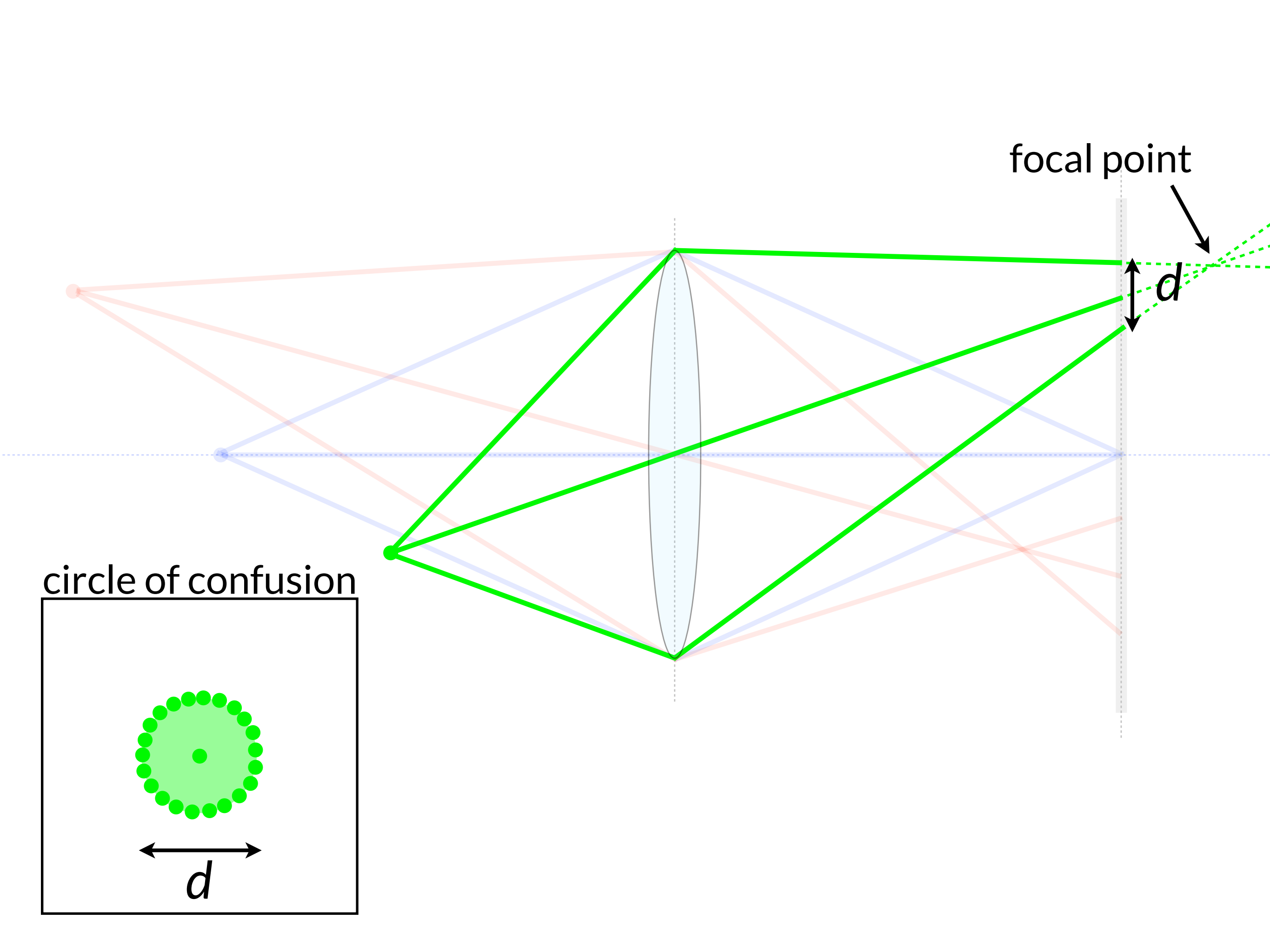

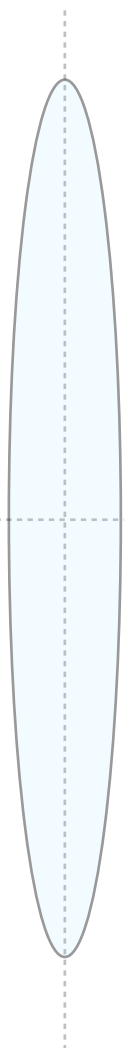



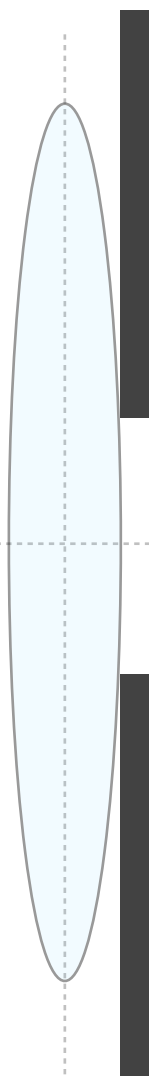

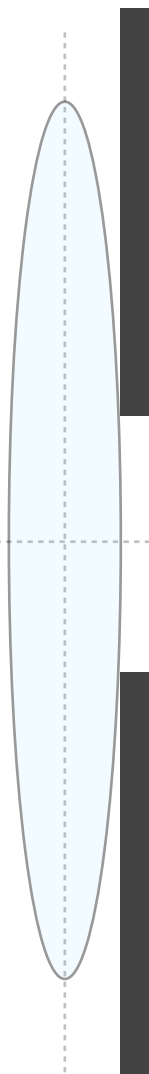

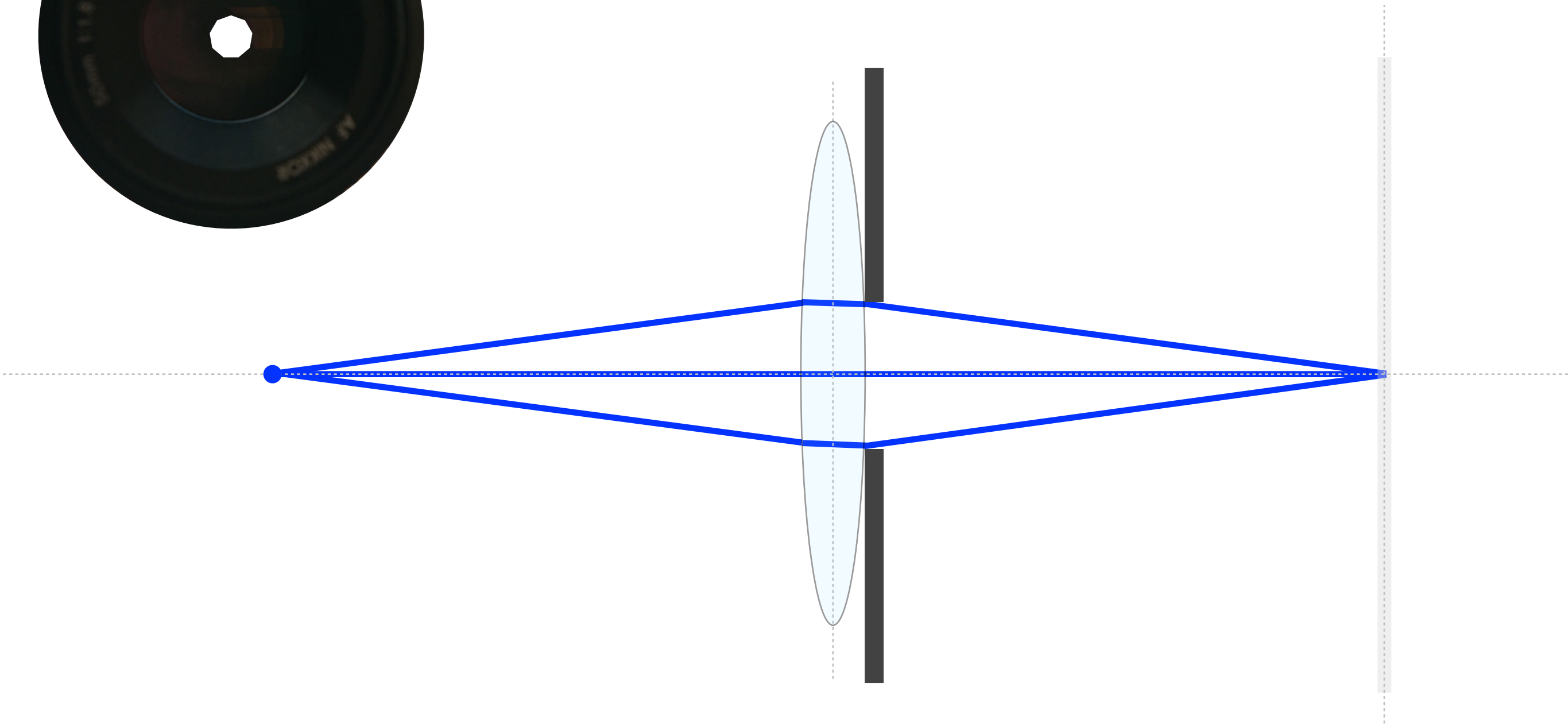

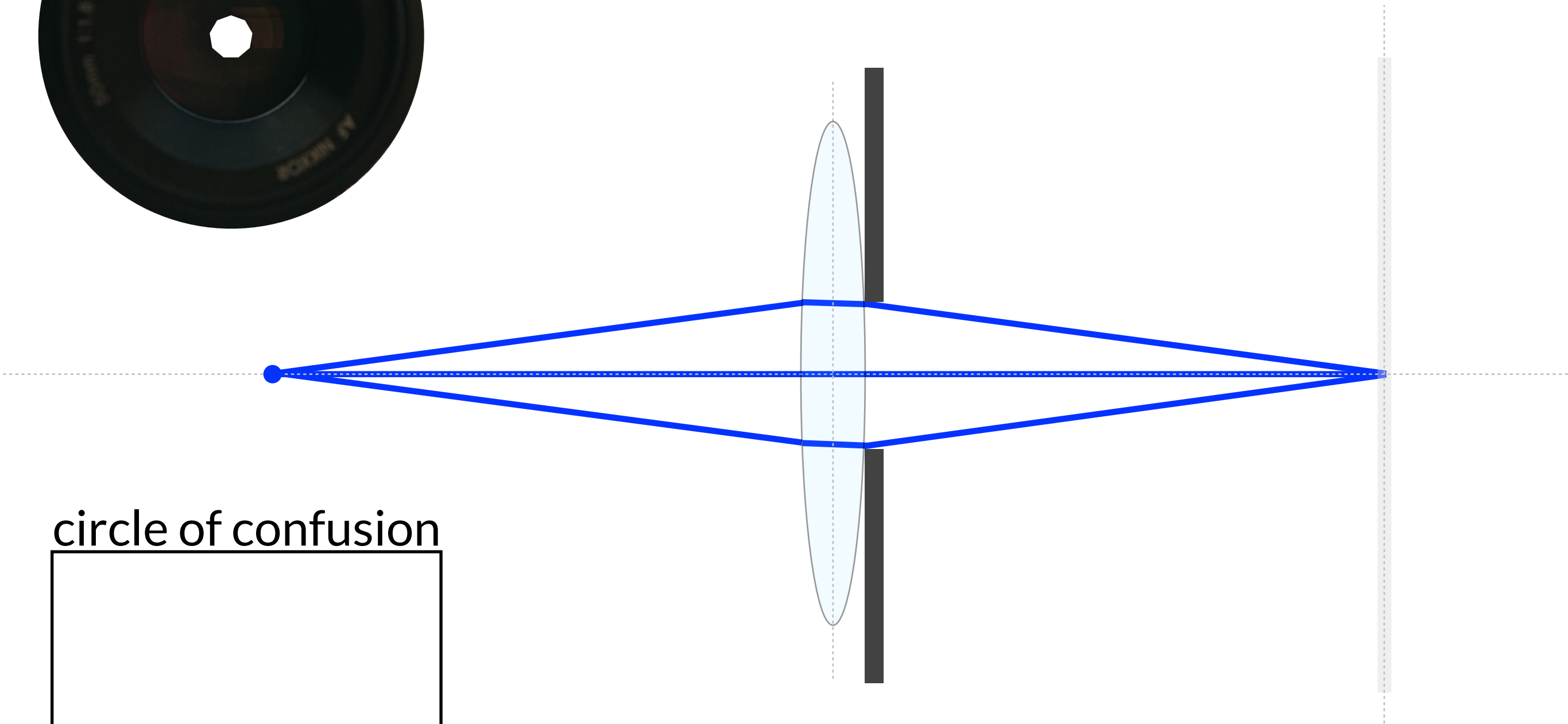

circle of confusion

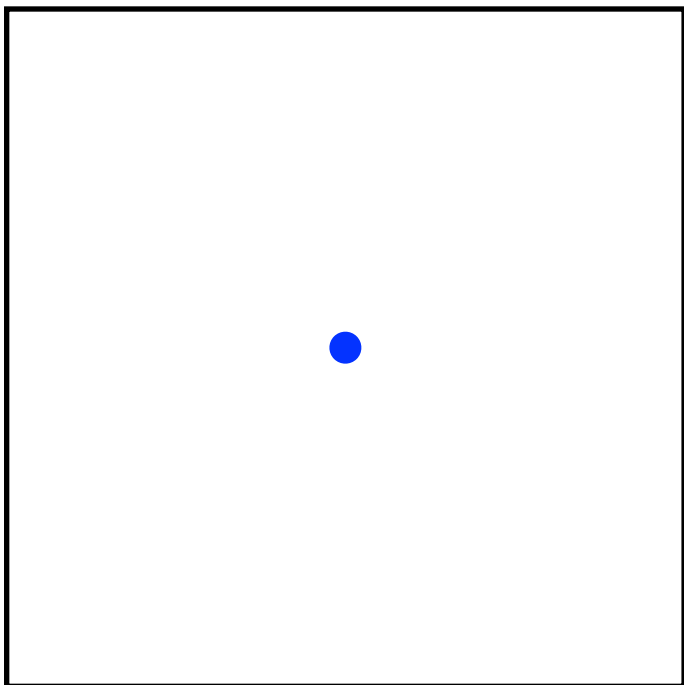

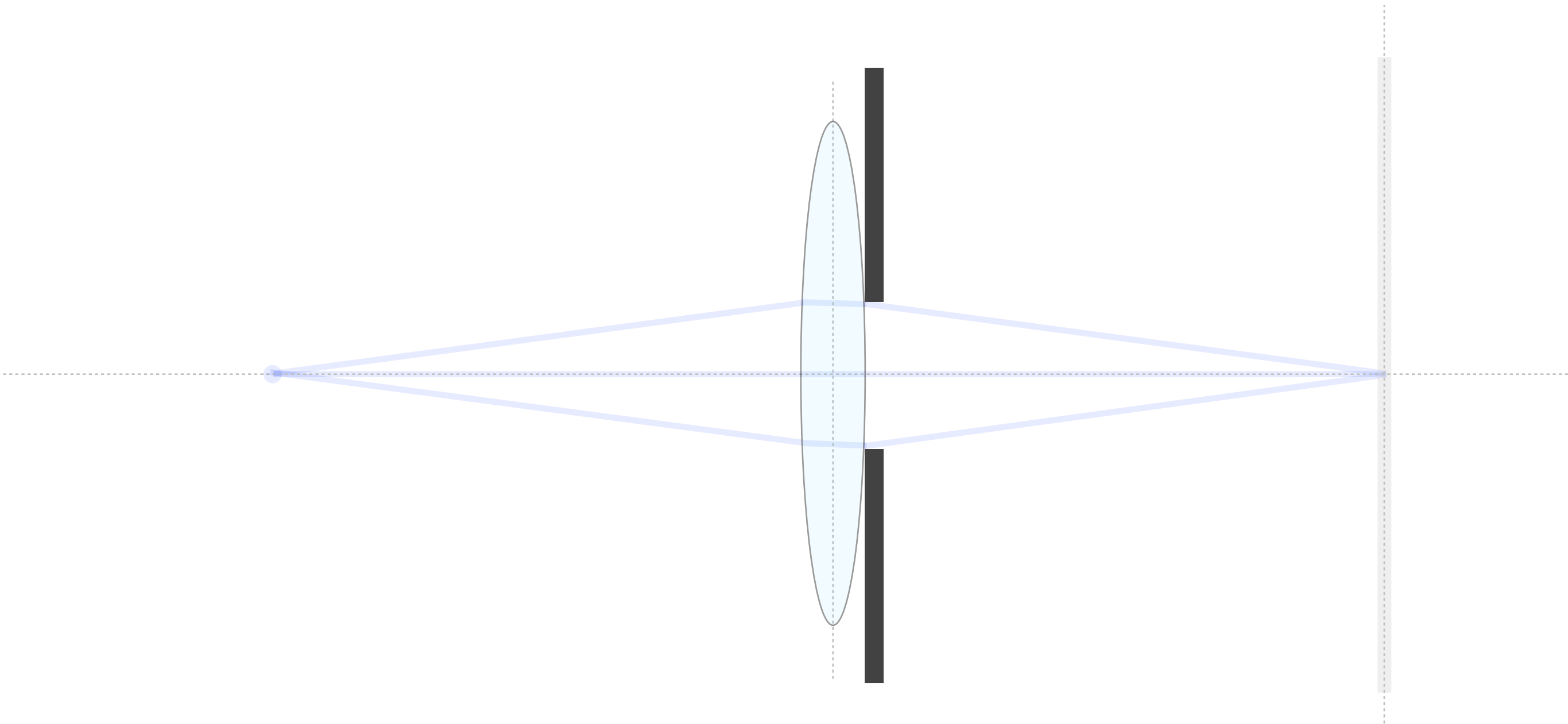

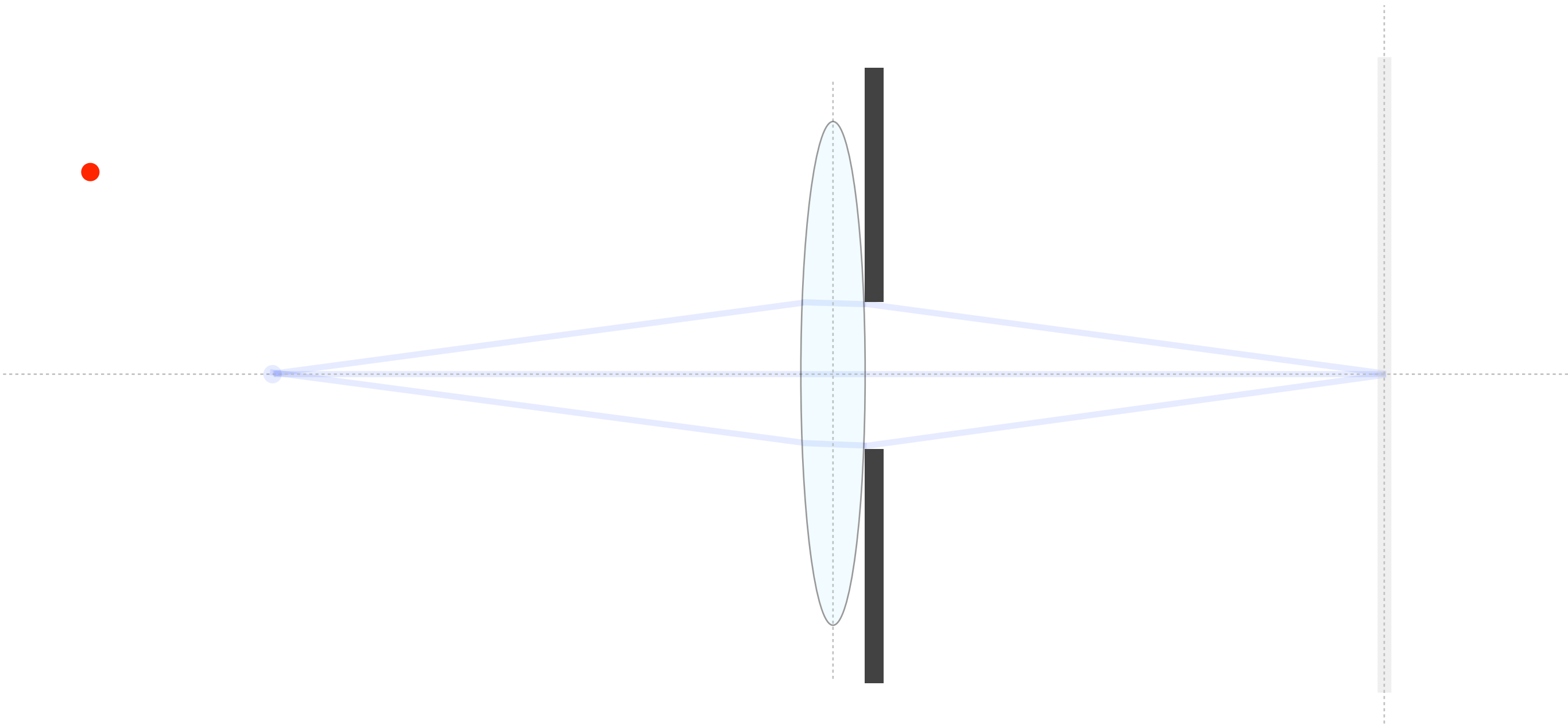

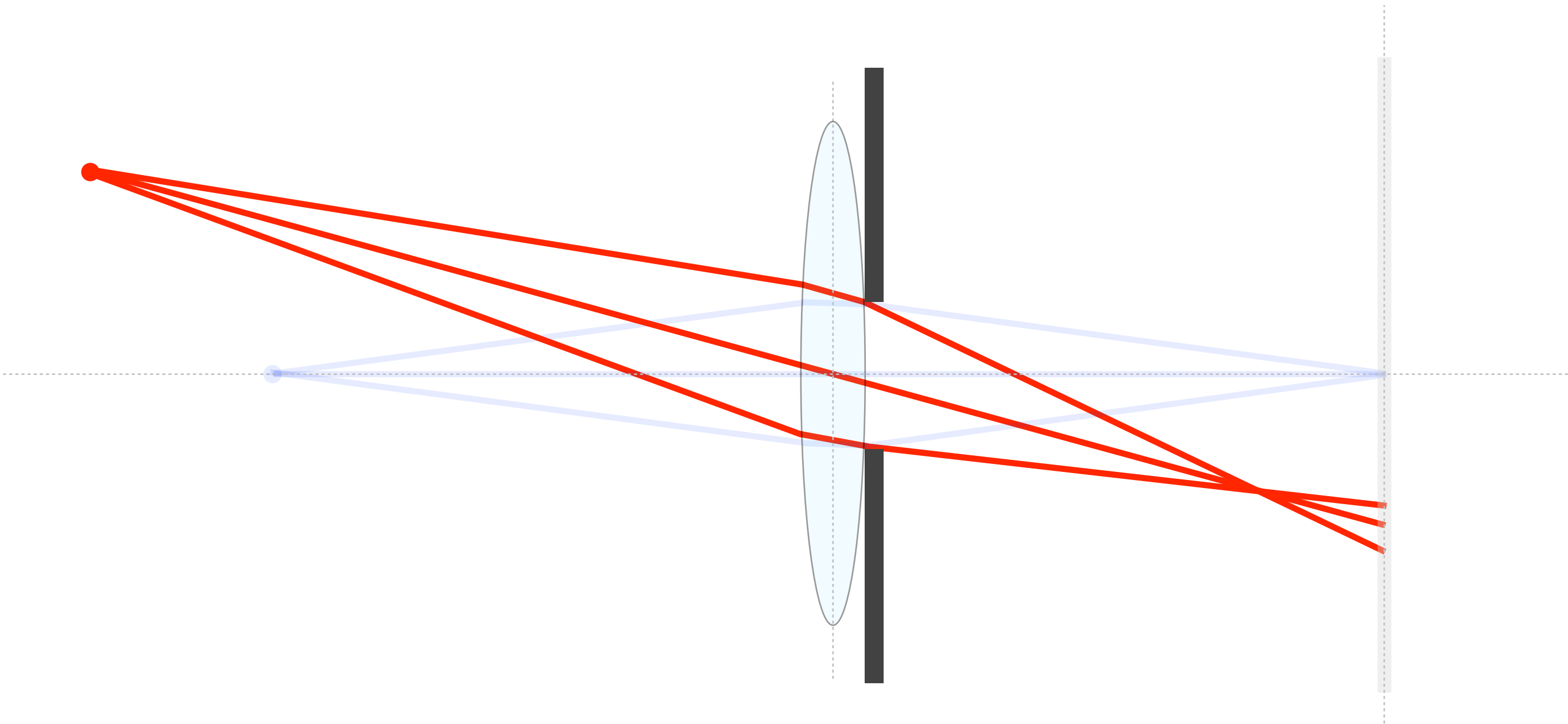

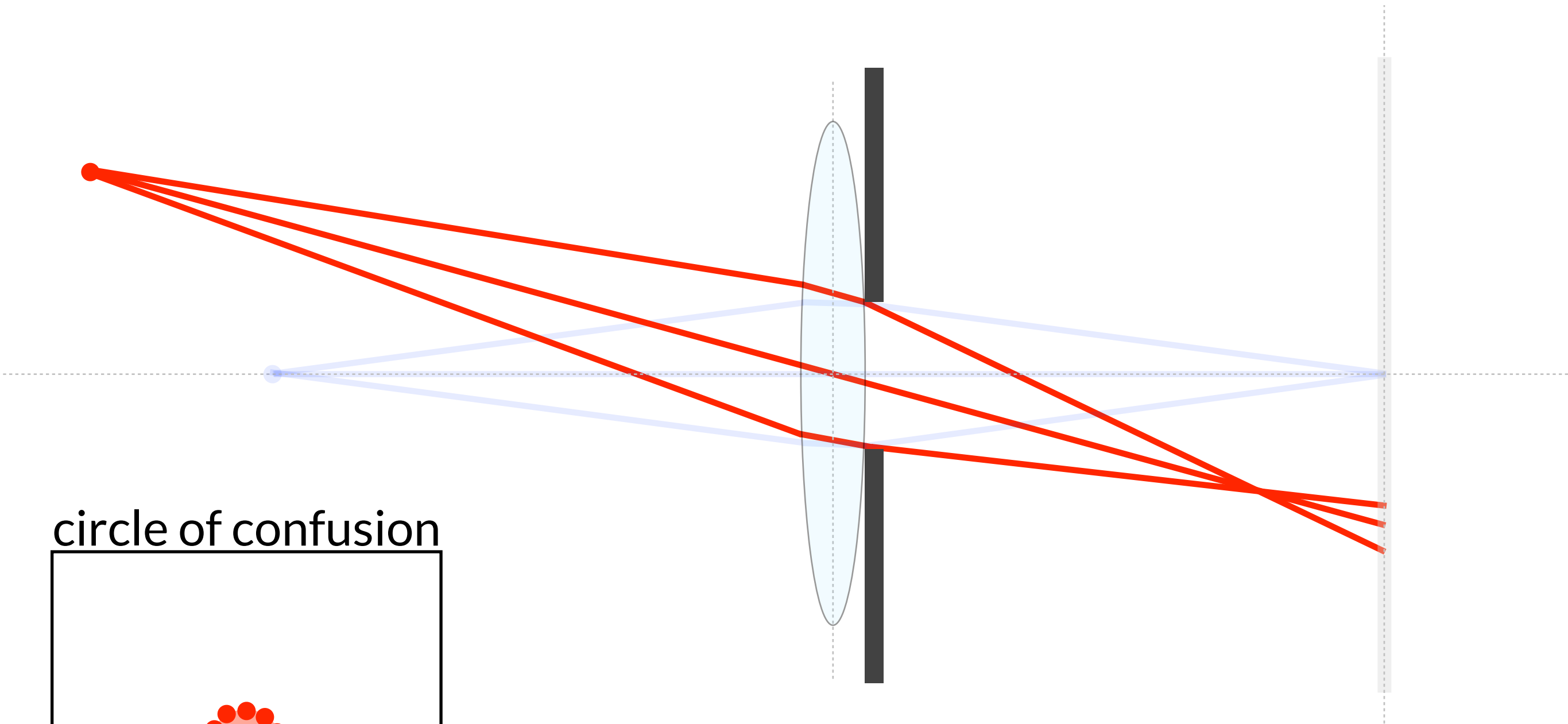

circle of confusion

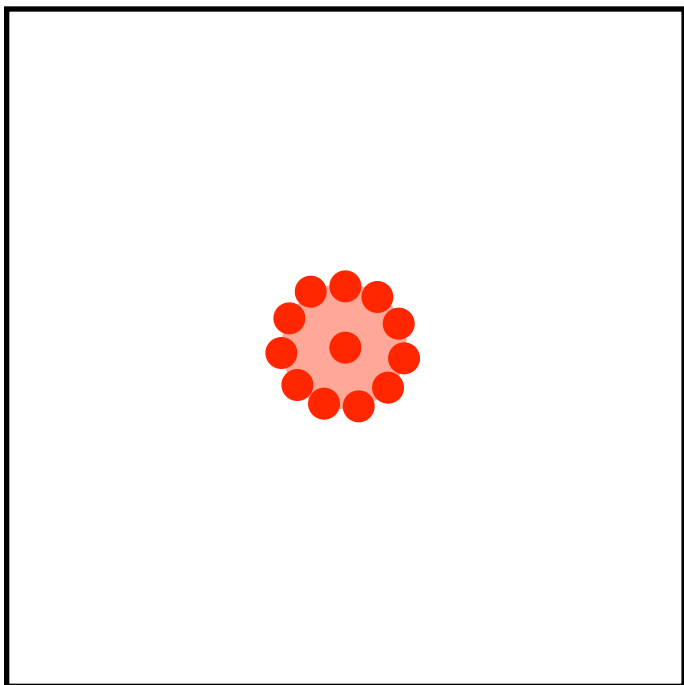



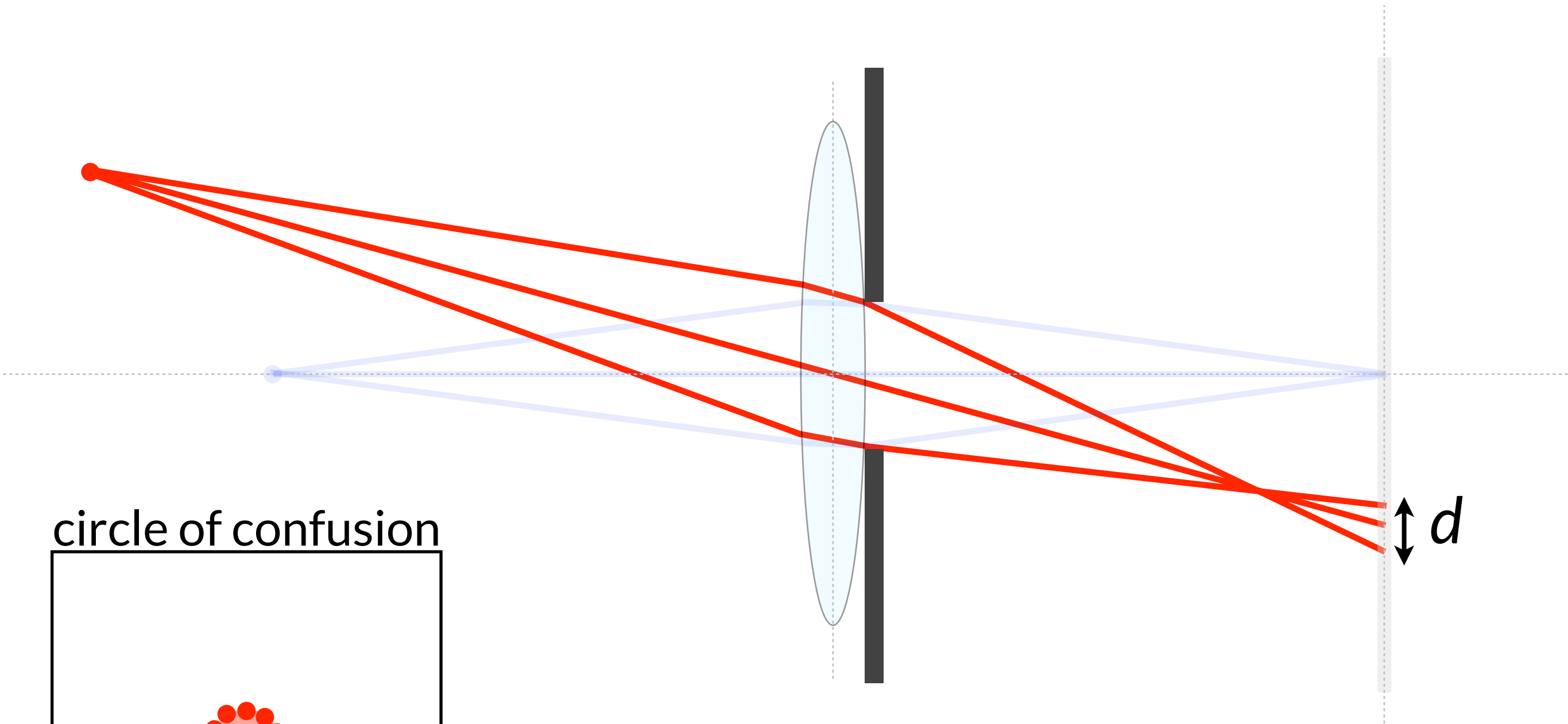

circle of confusion

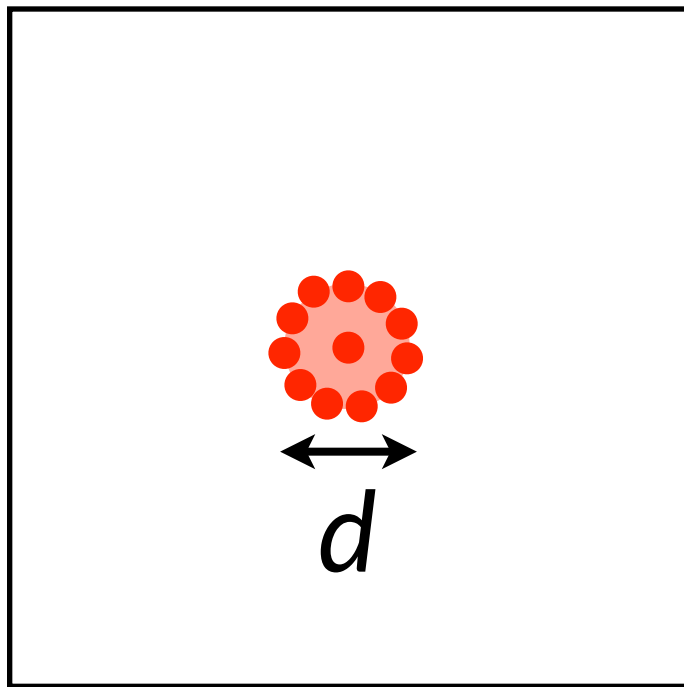

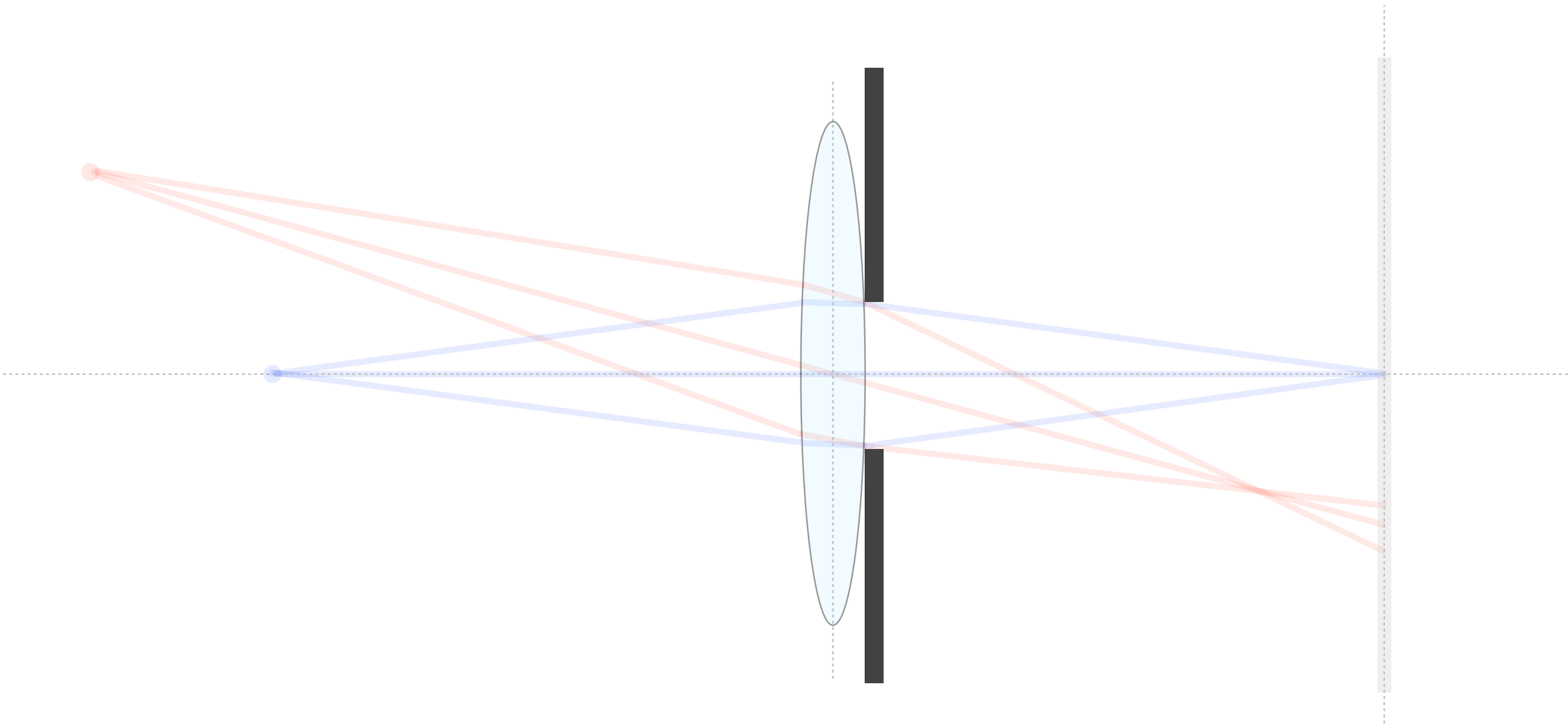

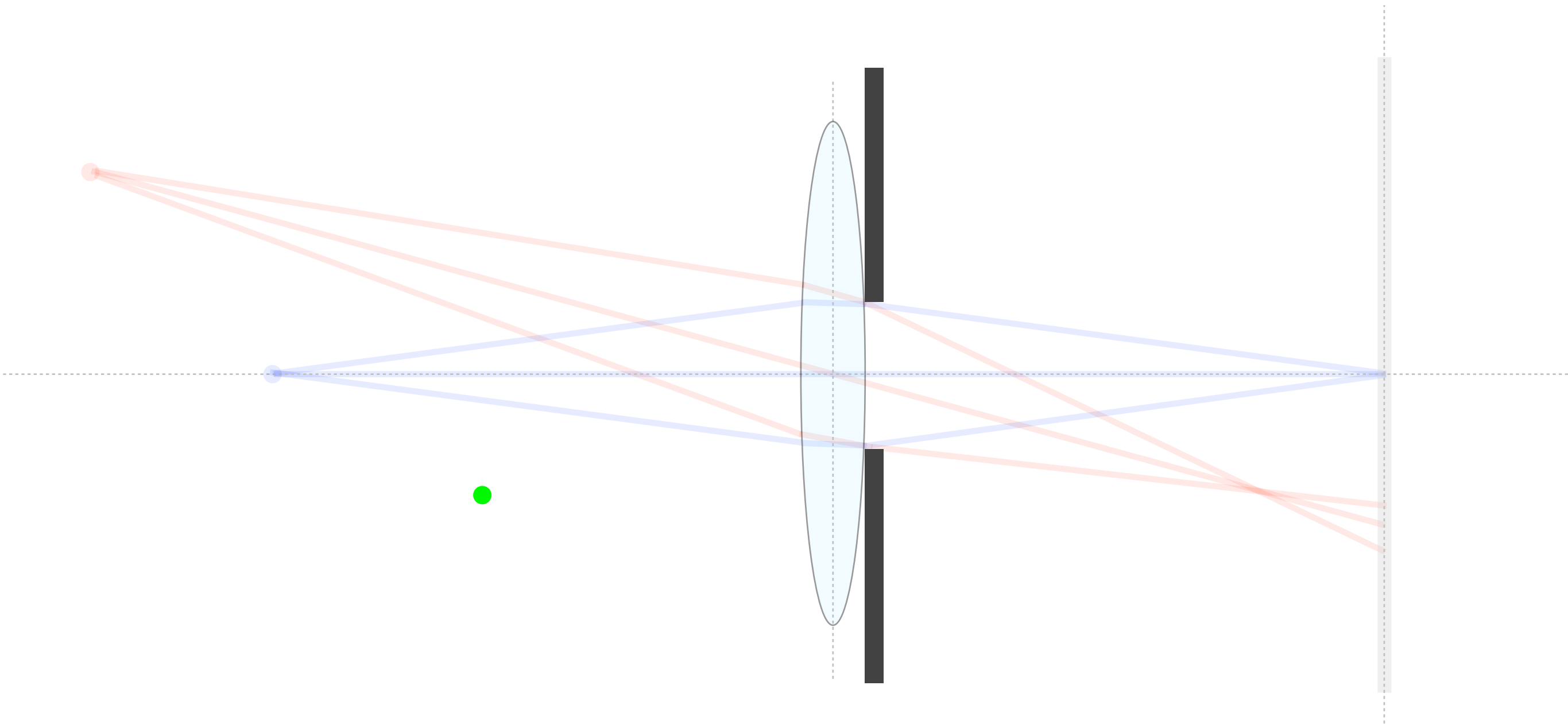

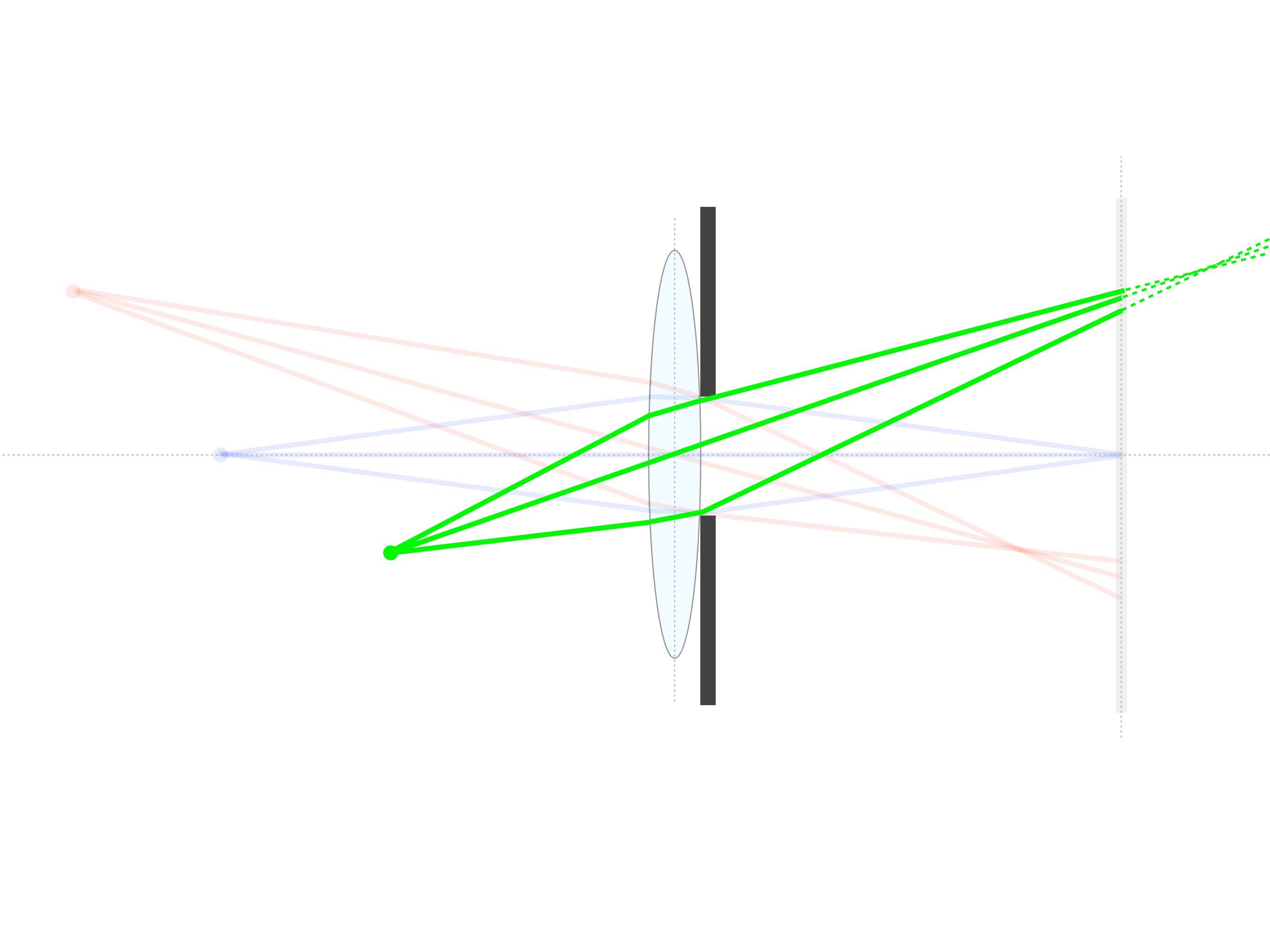

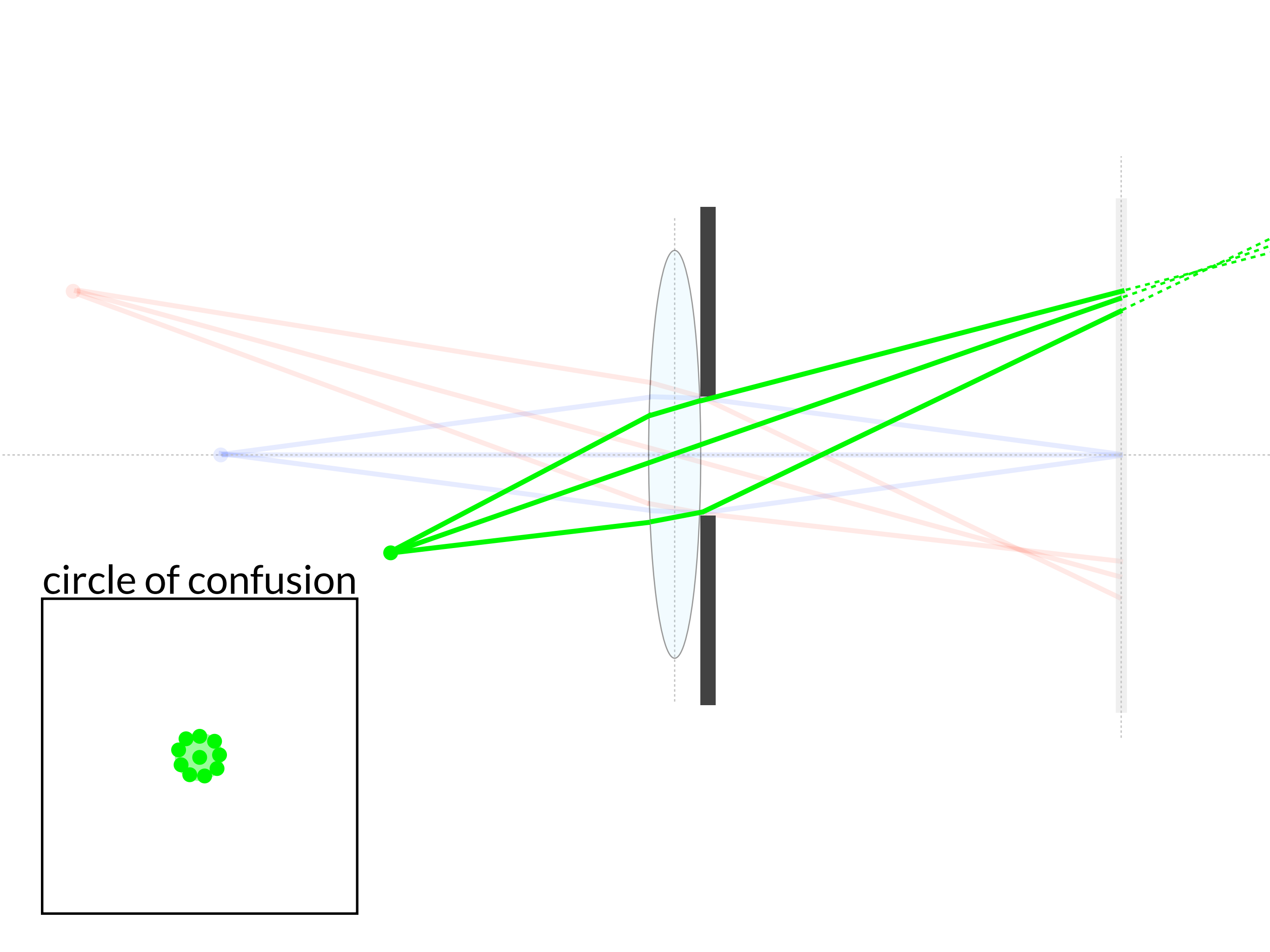

circle of confusion

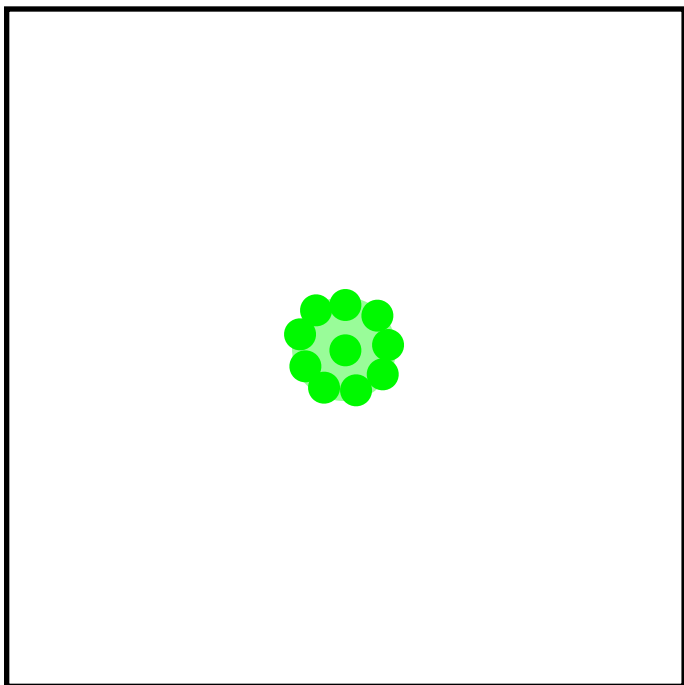

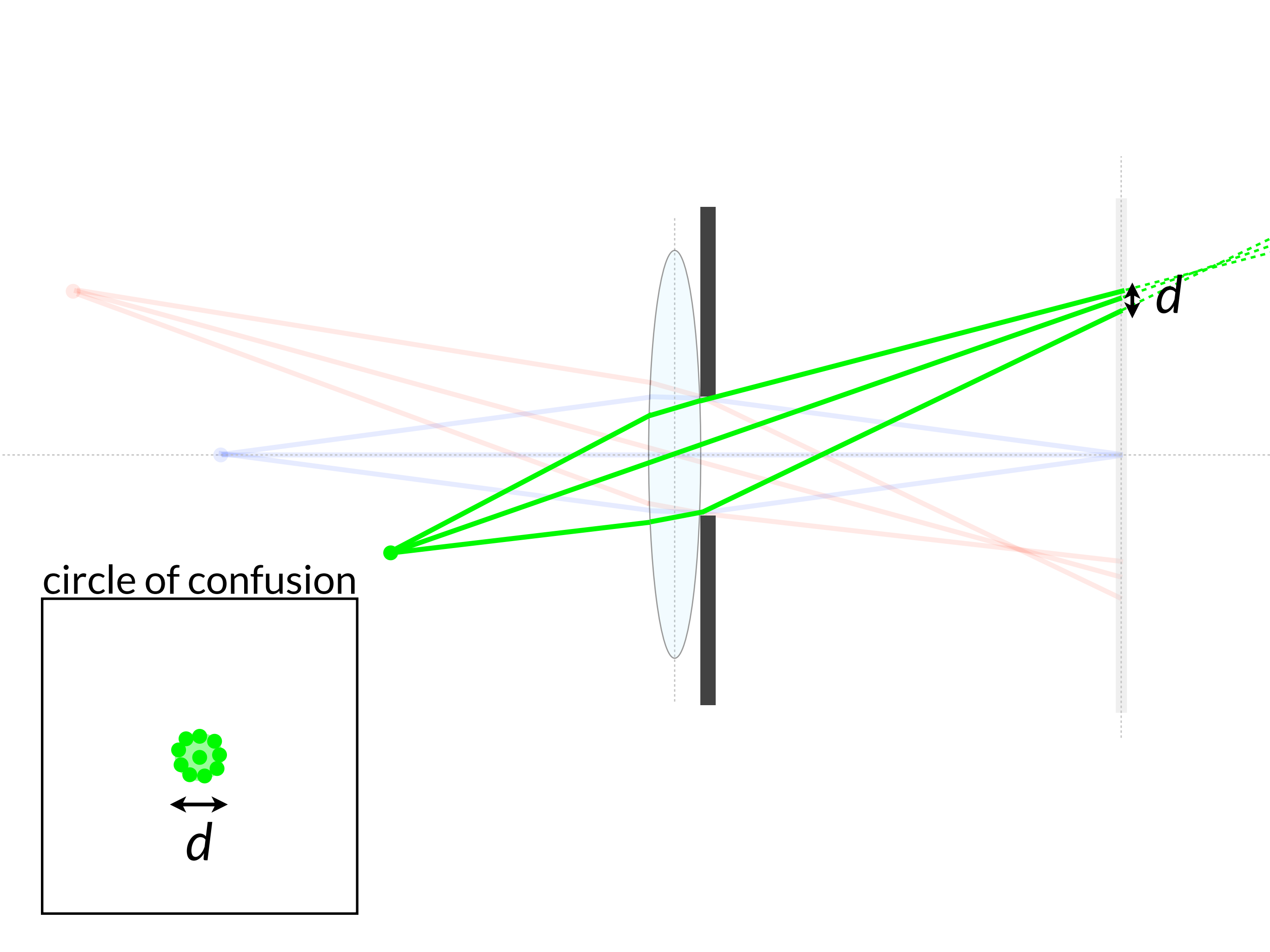

circle of confusion

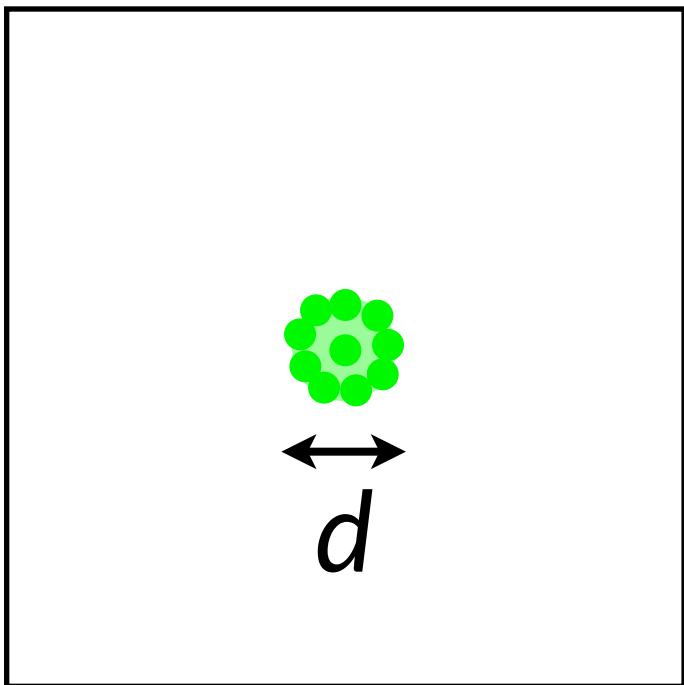

# Controlling Depth of Field

- size of aperture
- camera-to-subject distance

# Controlling Depth of Field

- size of aperture
- camera-to-subject distance



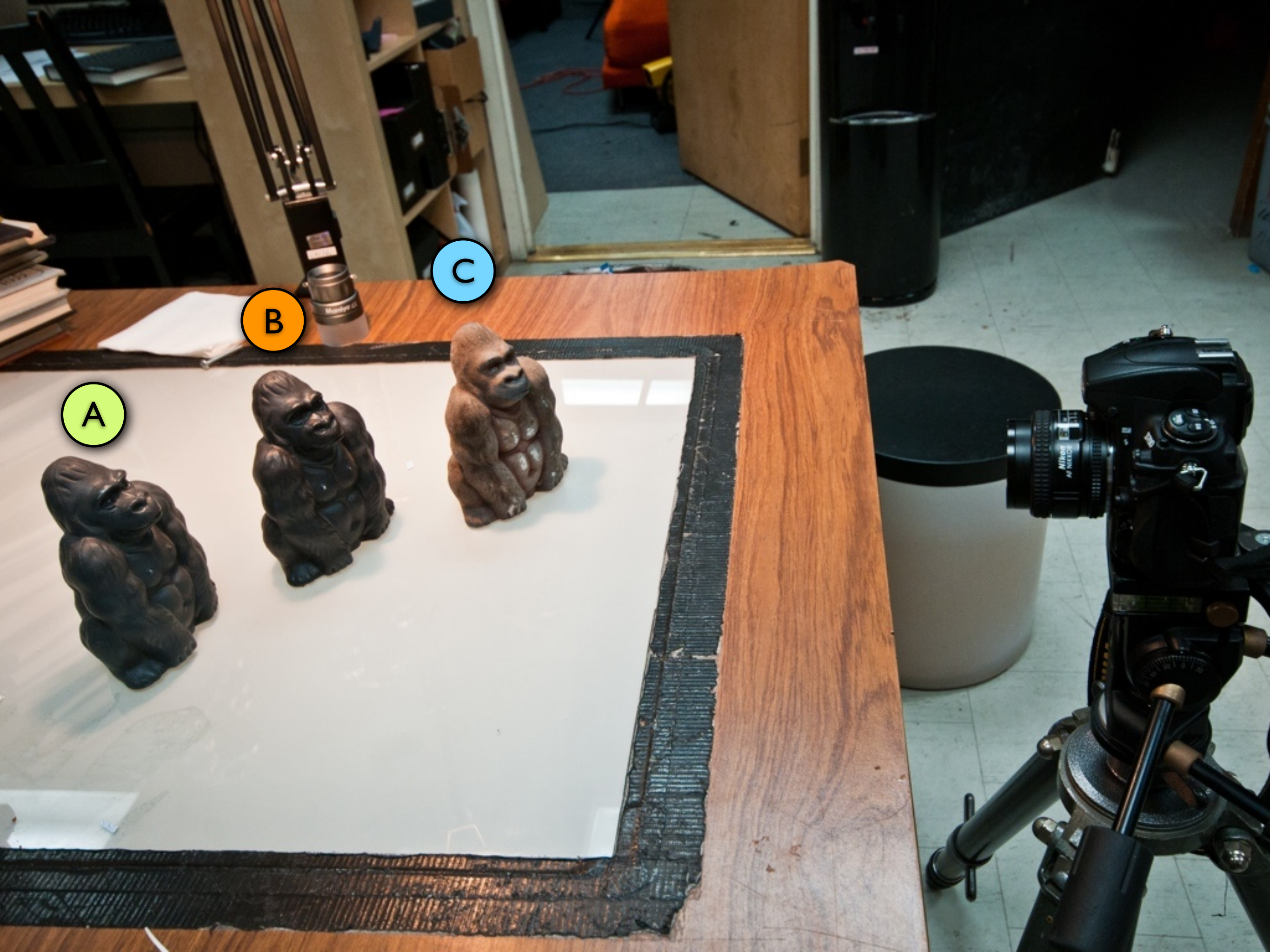

A

B

C





$f/1.4$

$1/60 \text{ sec}$



*f/1.4*

*1/60 sec*





*f/1.4*

*1/60 sec*





A

B

C





$f/1.4$

$1/80 \text{ sec}$



$f/1.4$

$1/80 \text{ sec}$





*f/1.4*

*1/80 sec*



A

B

C







$f/1.4$

$1/80 \text{ sec}$



$f/1.4$

$1/80 \text{ sec}$





$f/1.4$

$1/80 \text{ sec}$

When to use **narrow** DoF?

When to use **wide** DoF?