

MIT Student Art Association IAP 2011

Digital Photography 101

introductions + 5 images



Huygens' Principle

The fundamentals of optics.

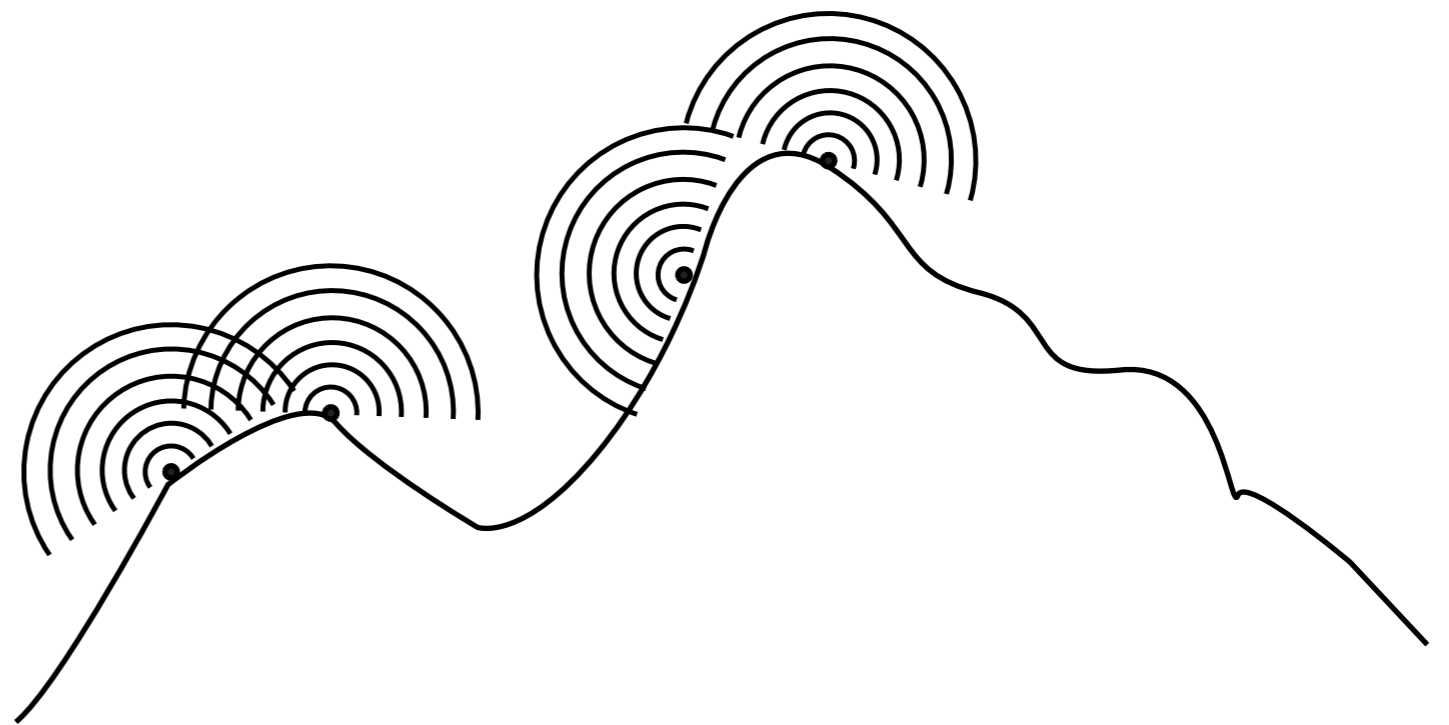
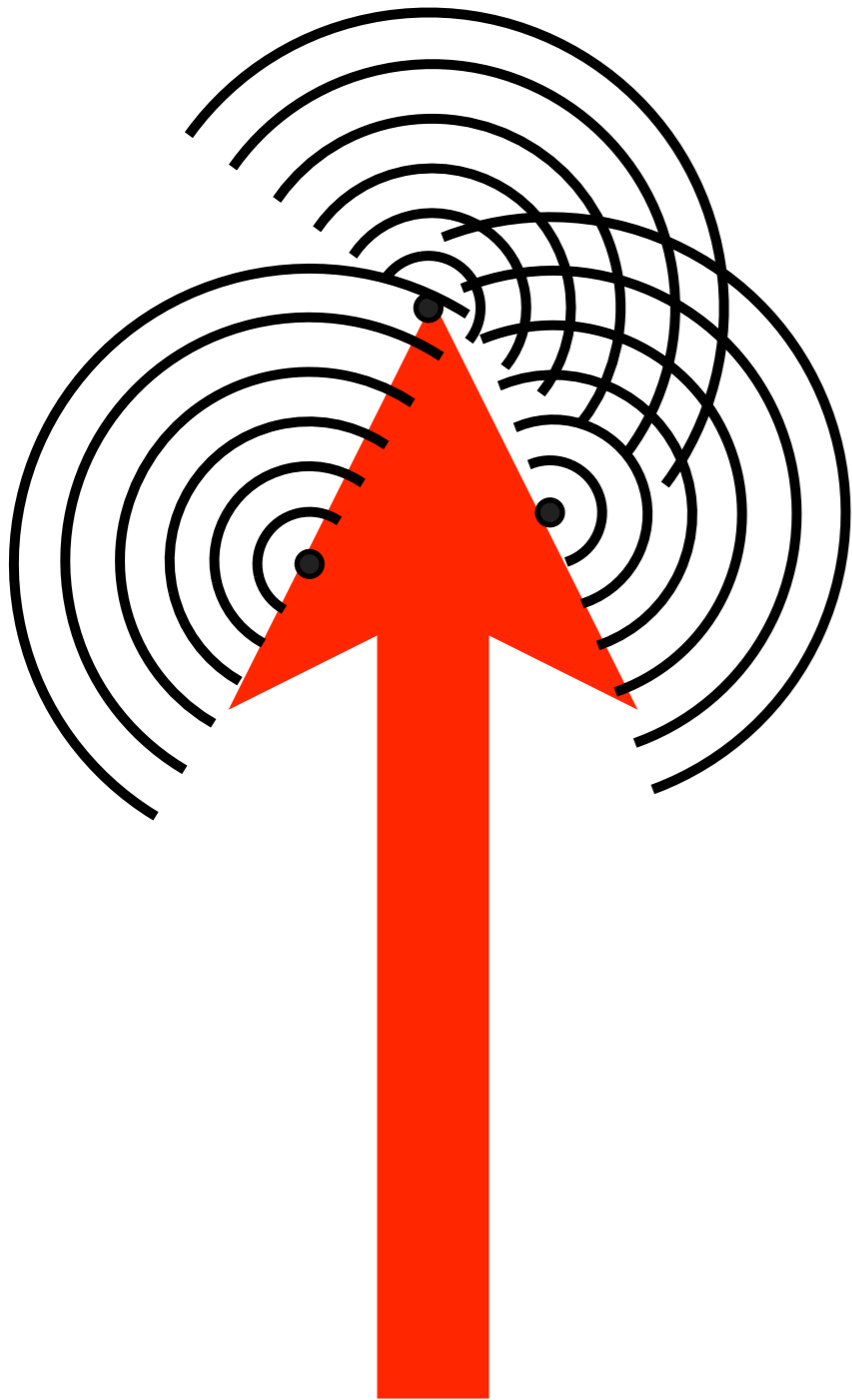



object

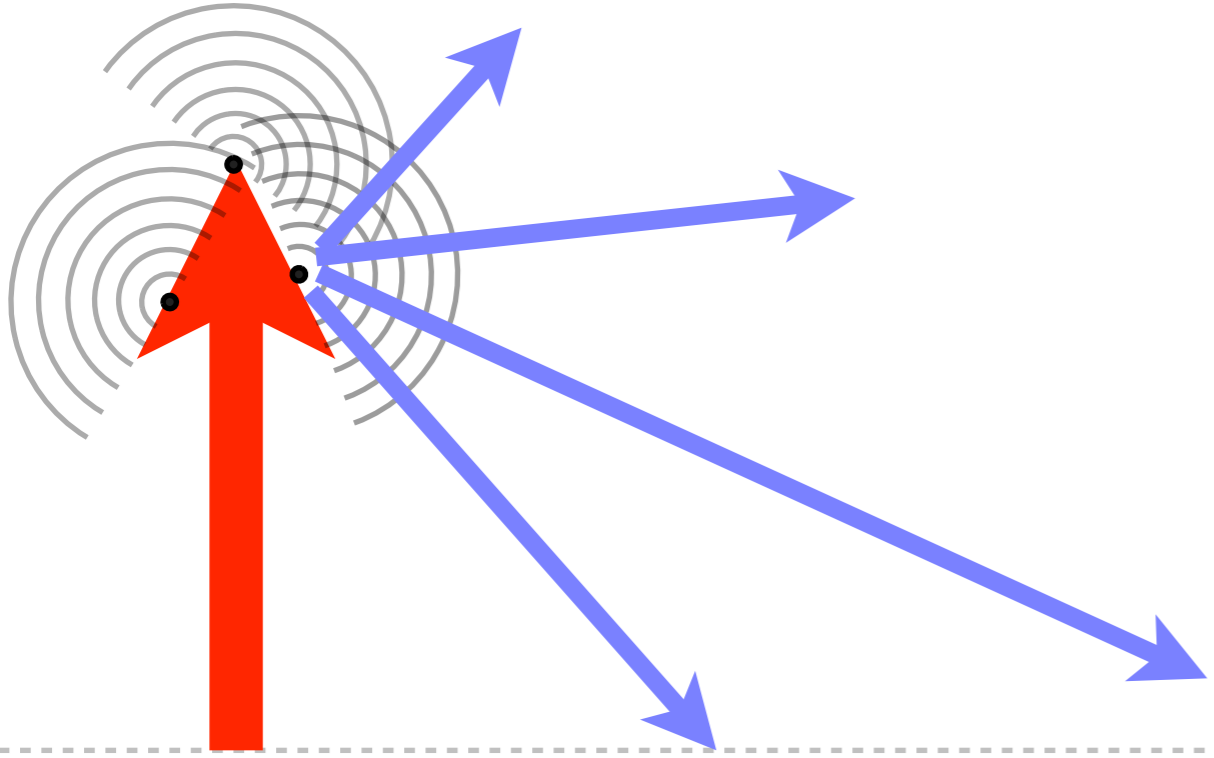

object

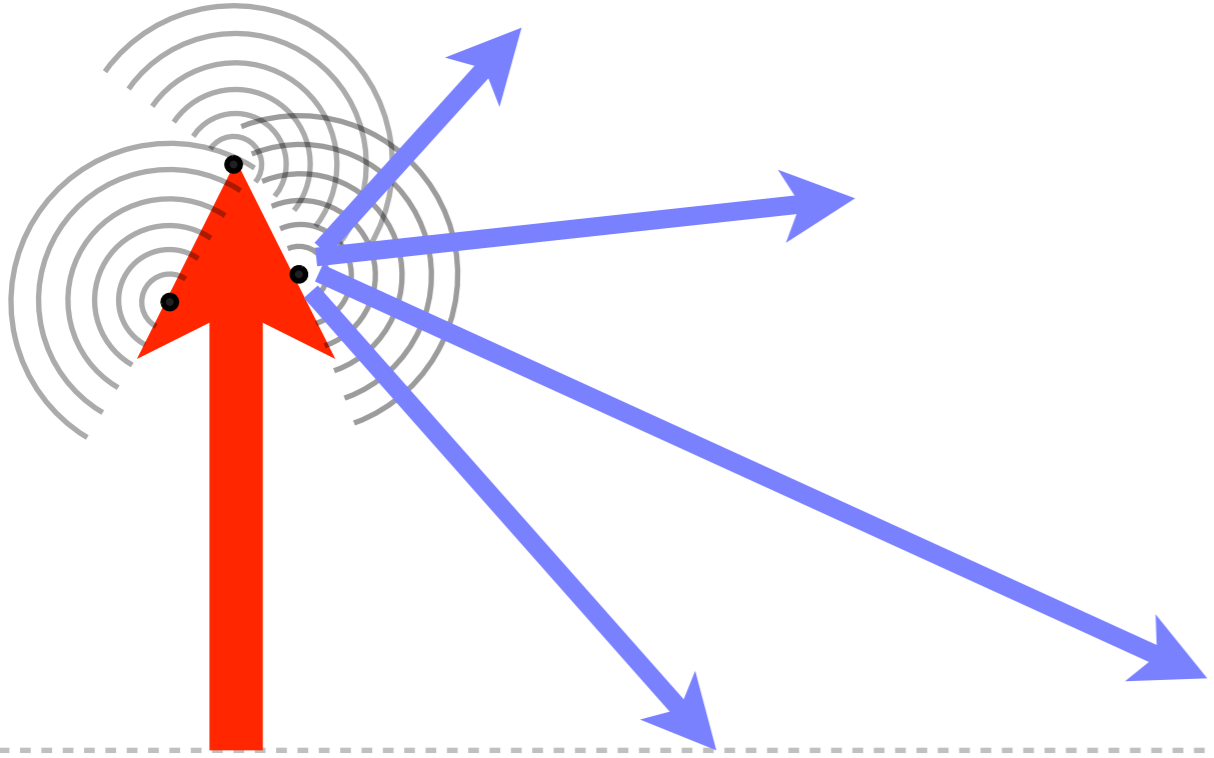

object

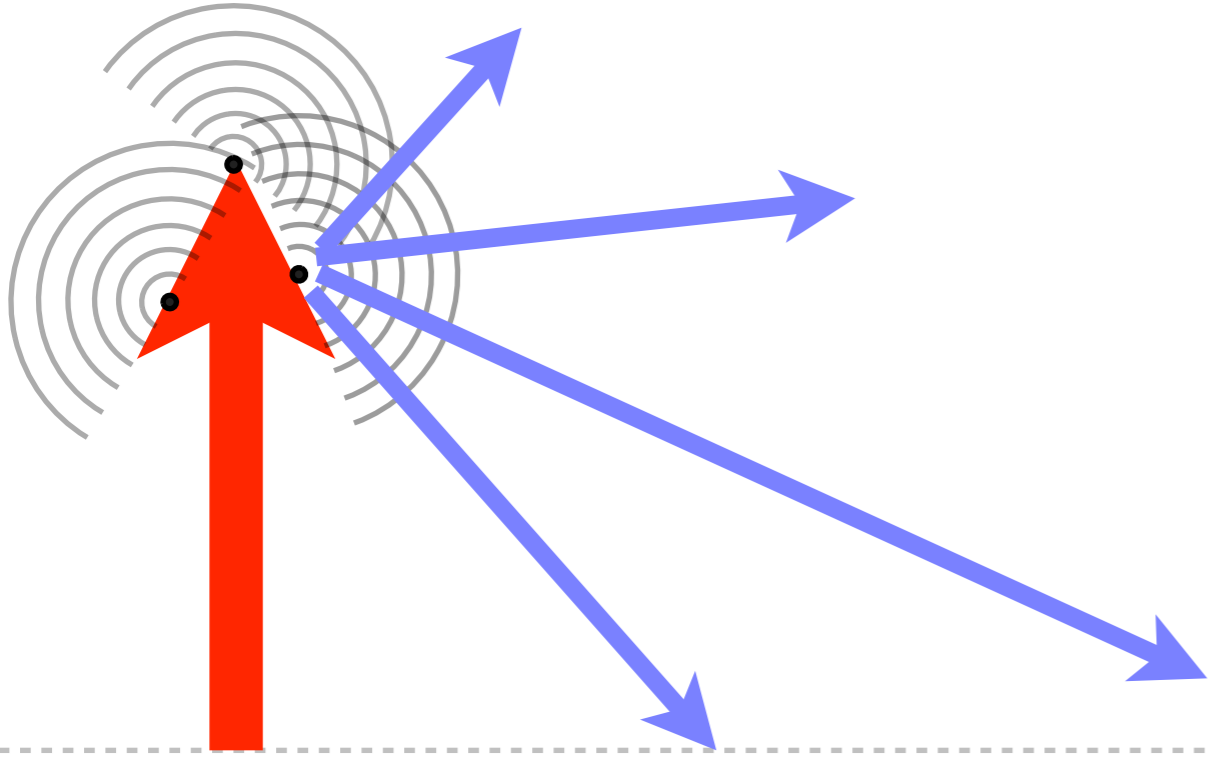

object



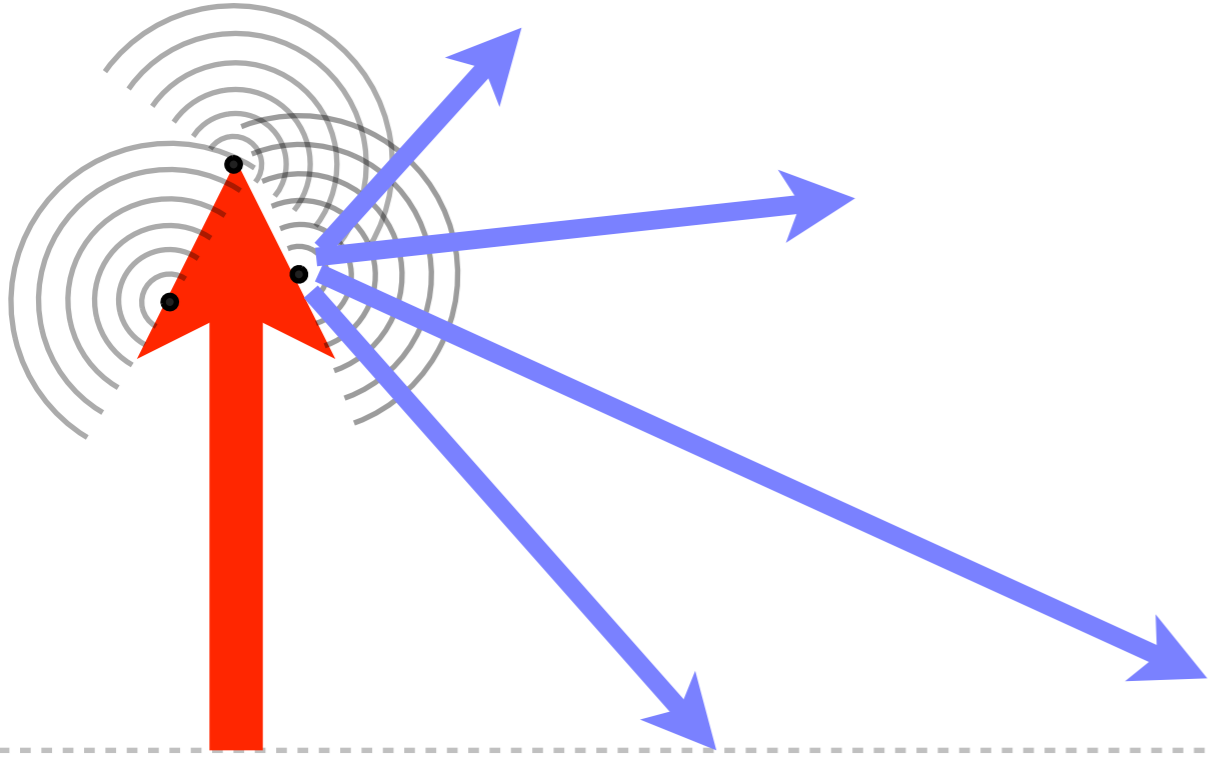

object

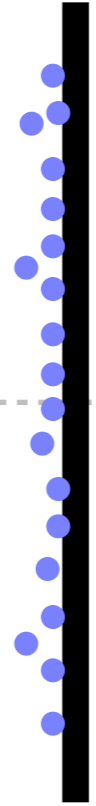

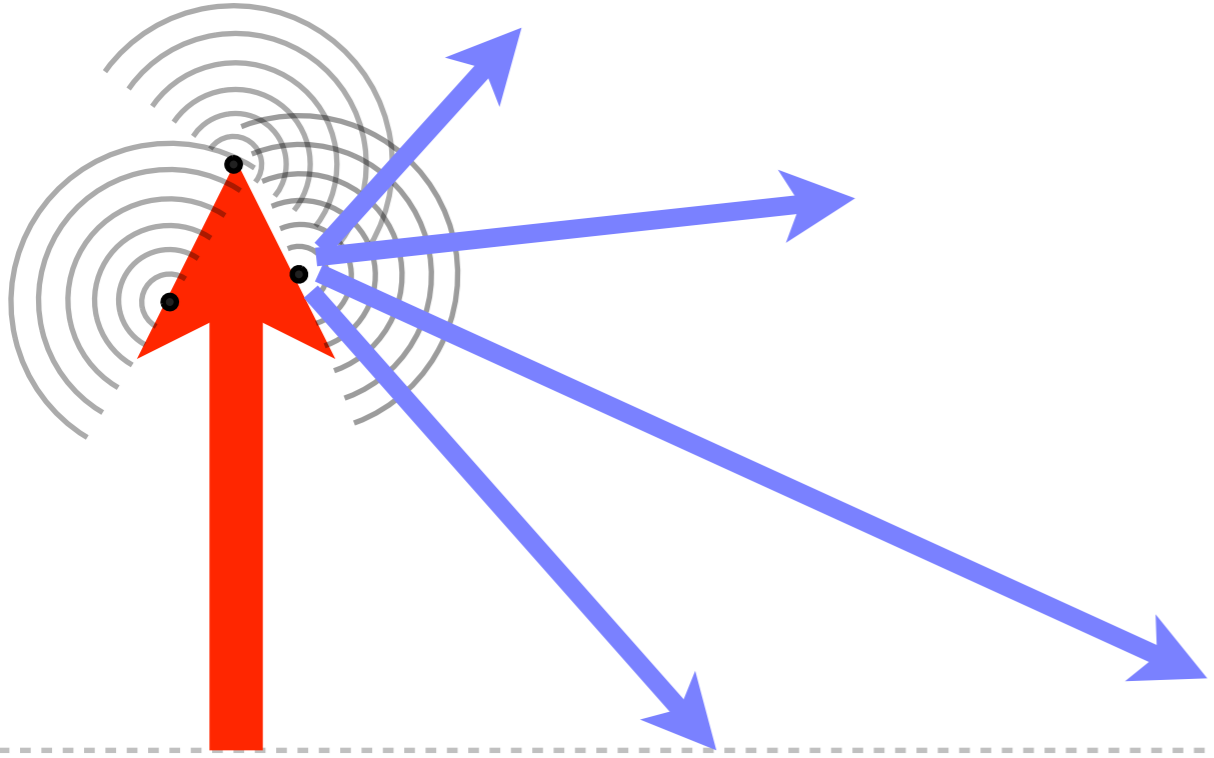

object

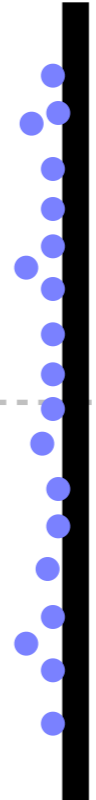

!= image



object

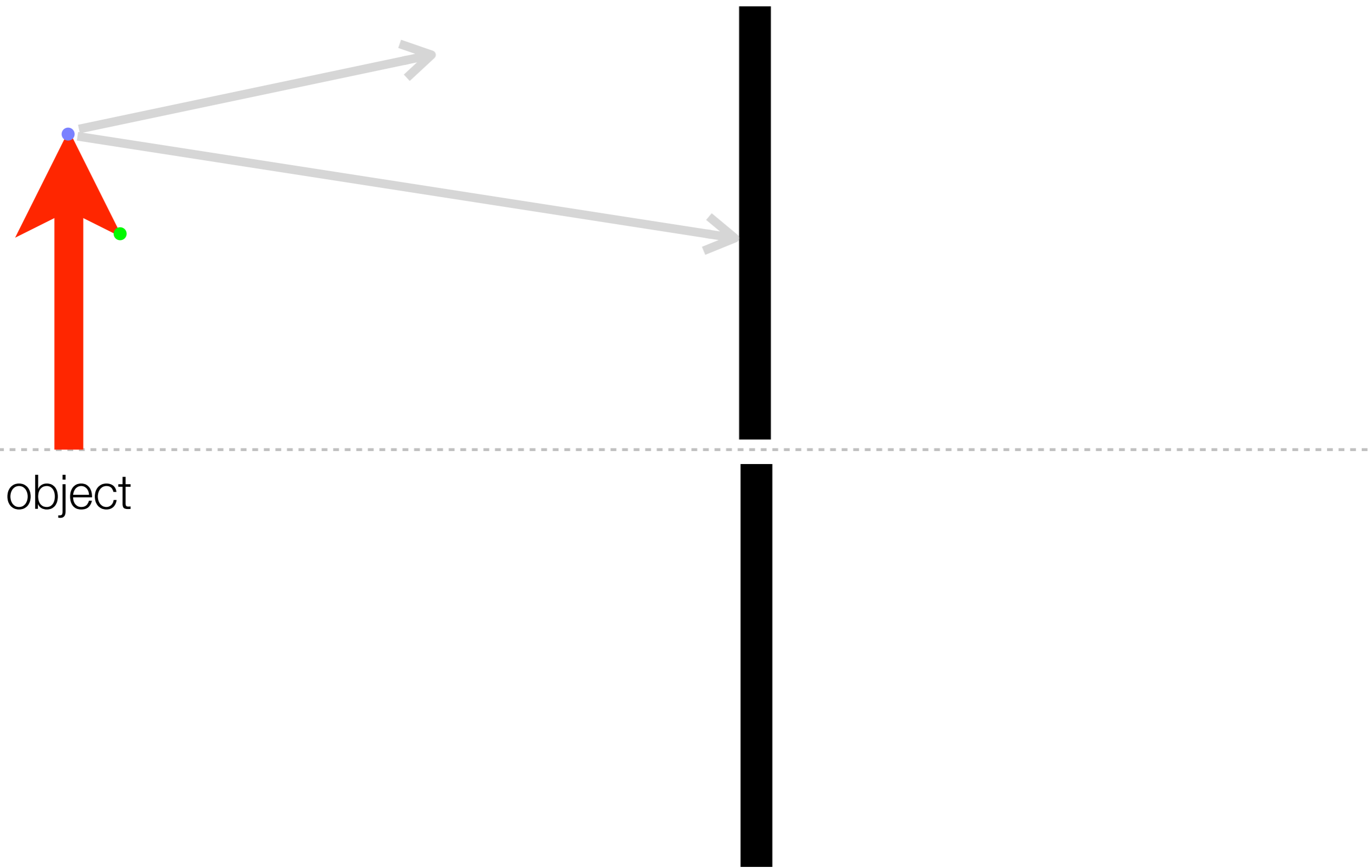

object



object

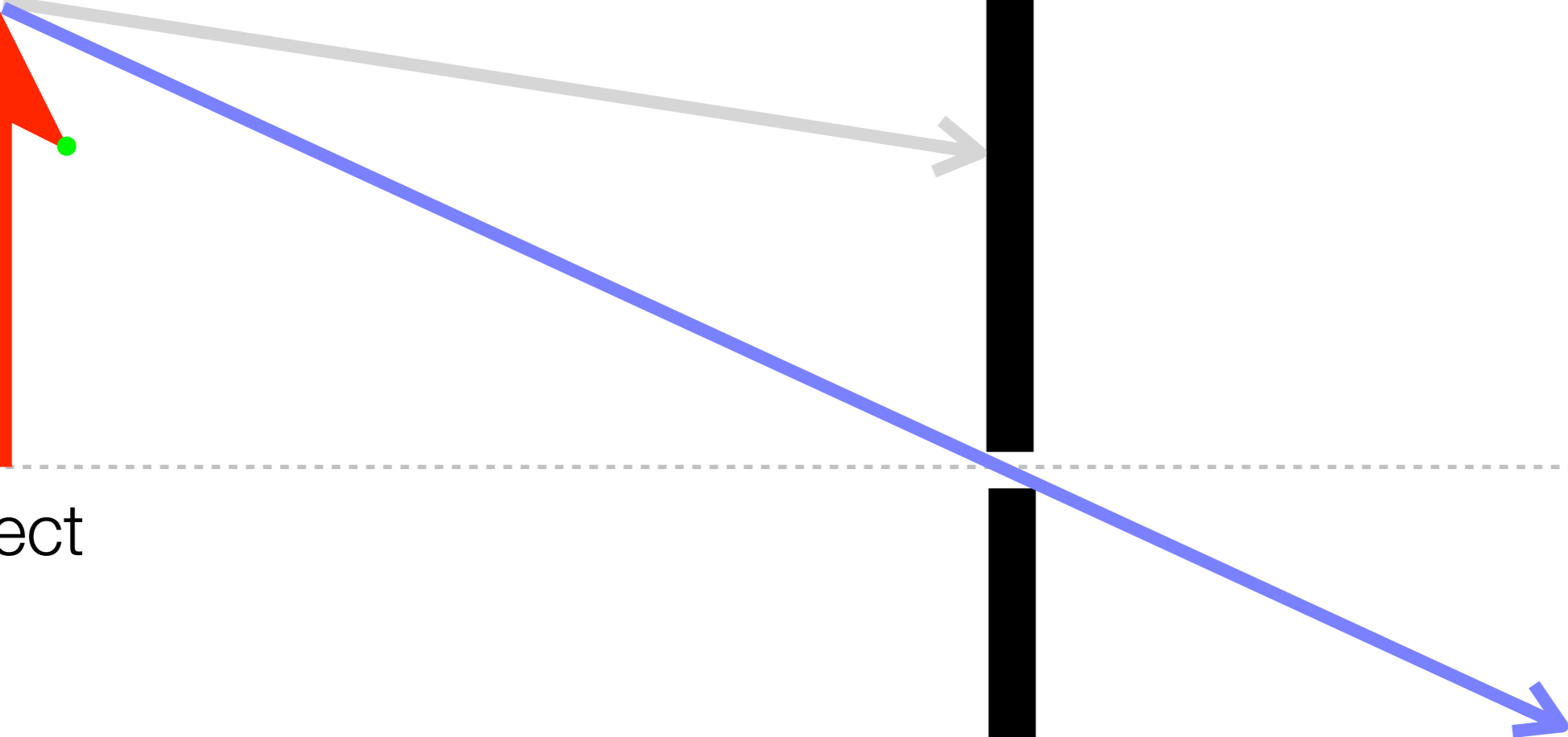
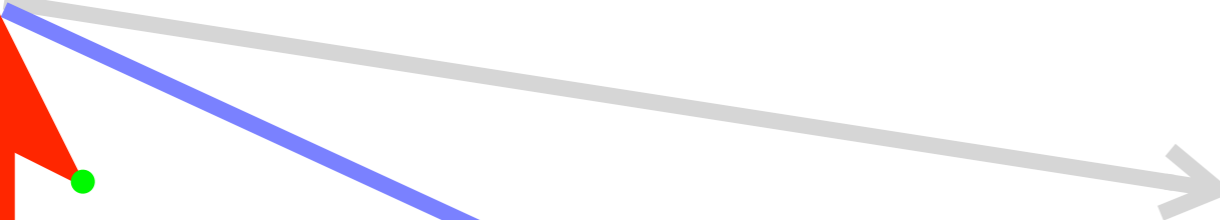

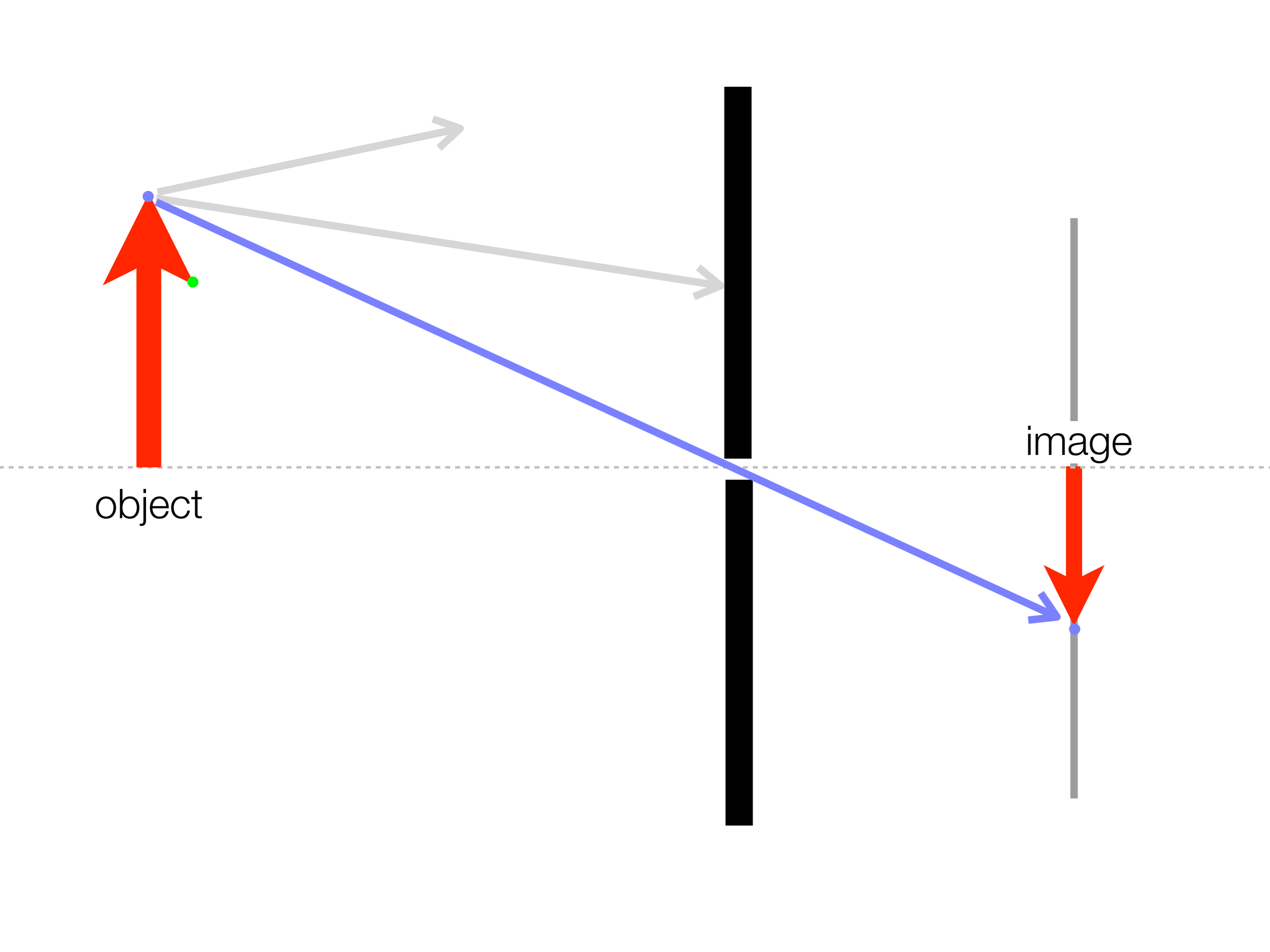

object

image

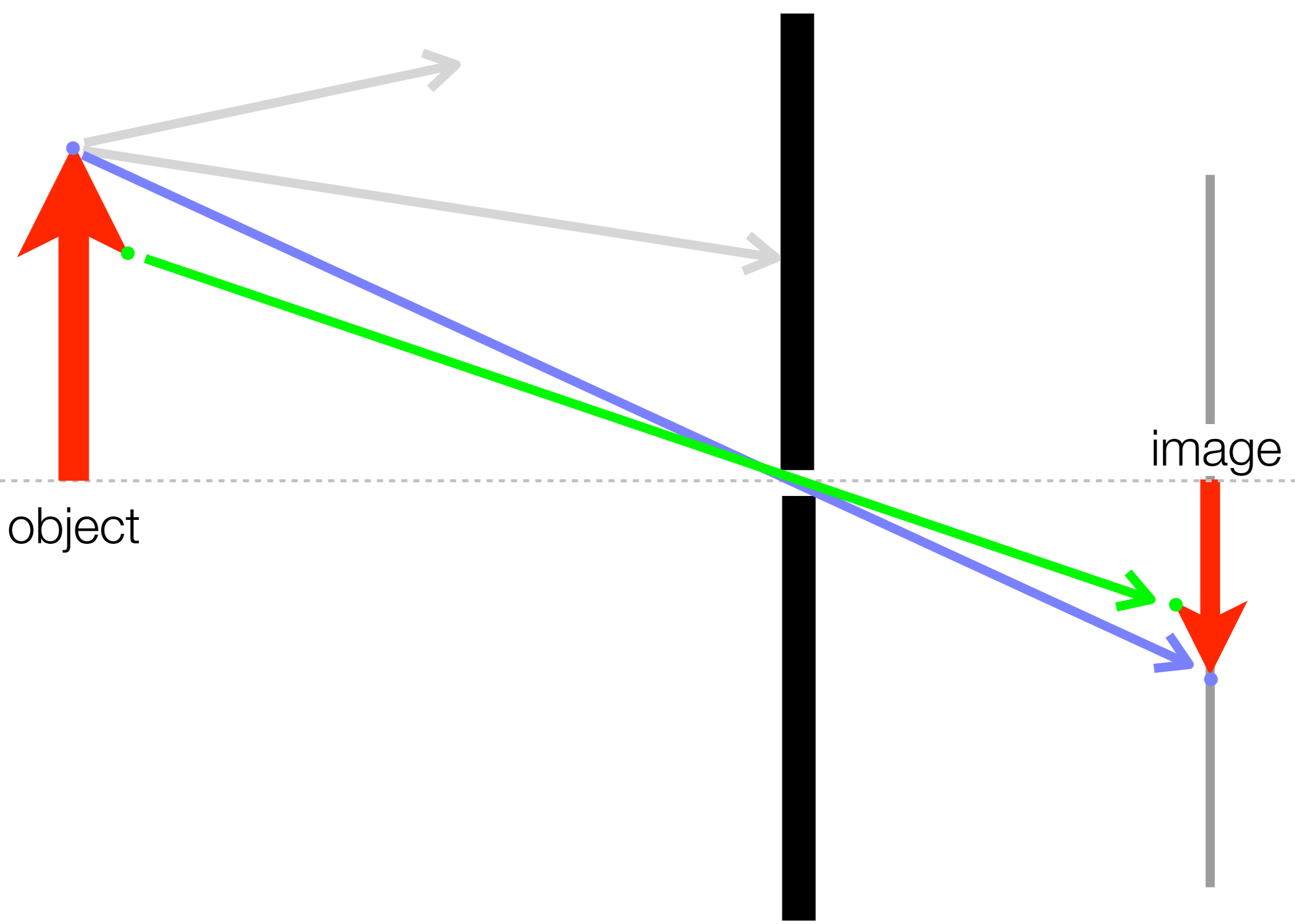

object

image



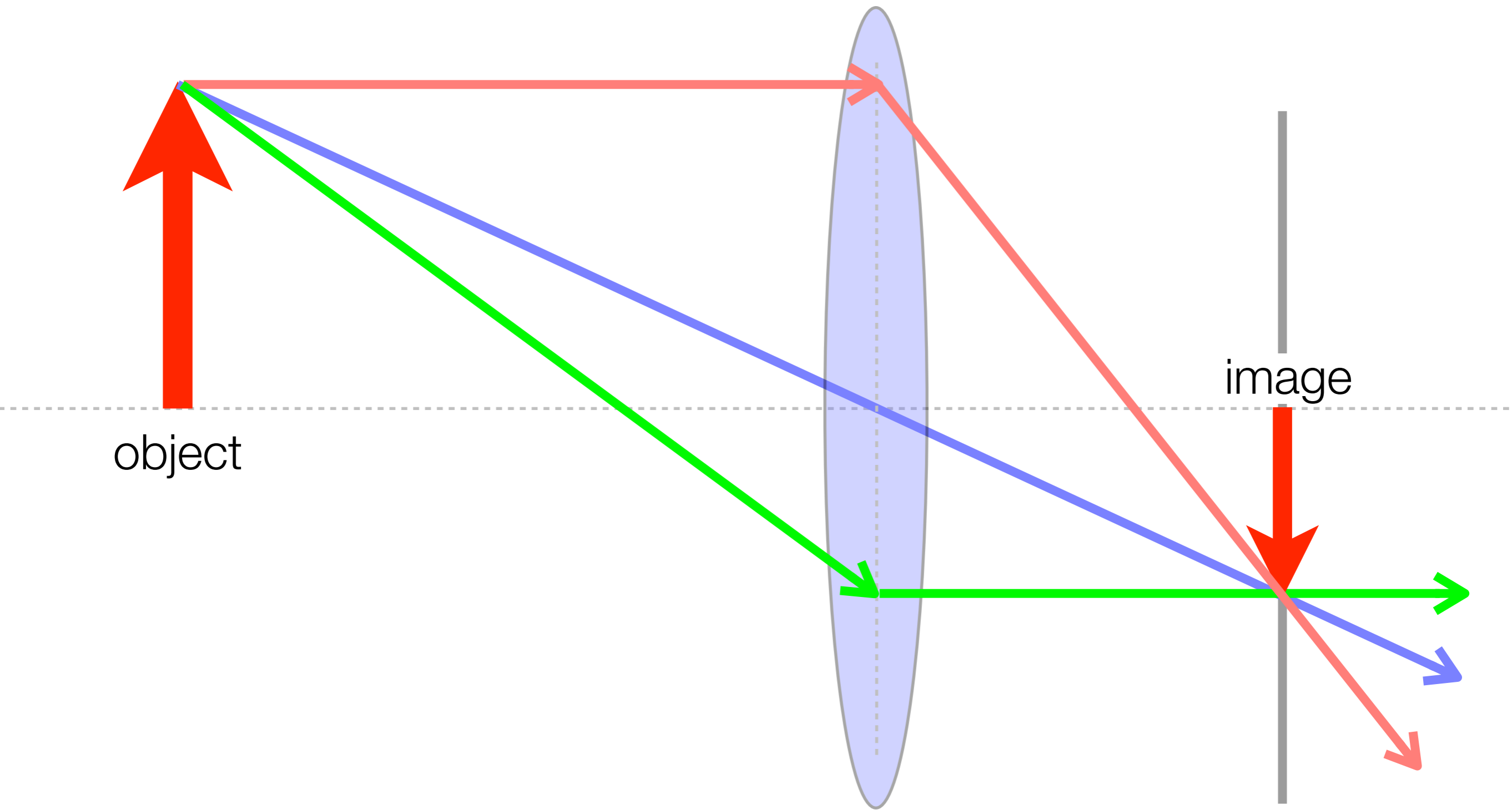

object

image

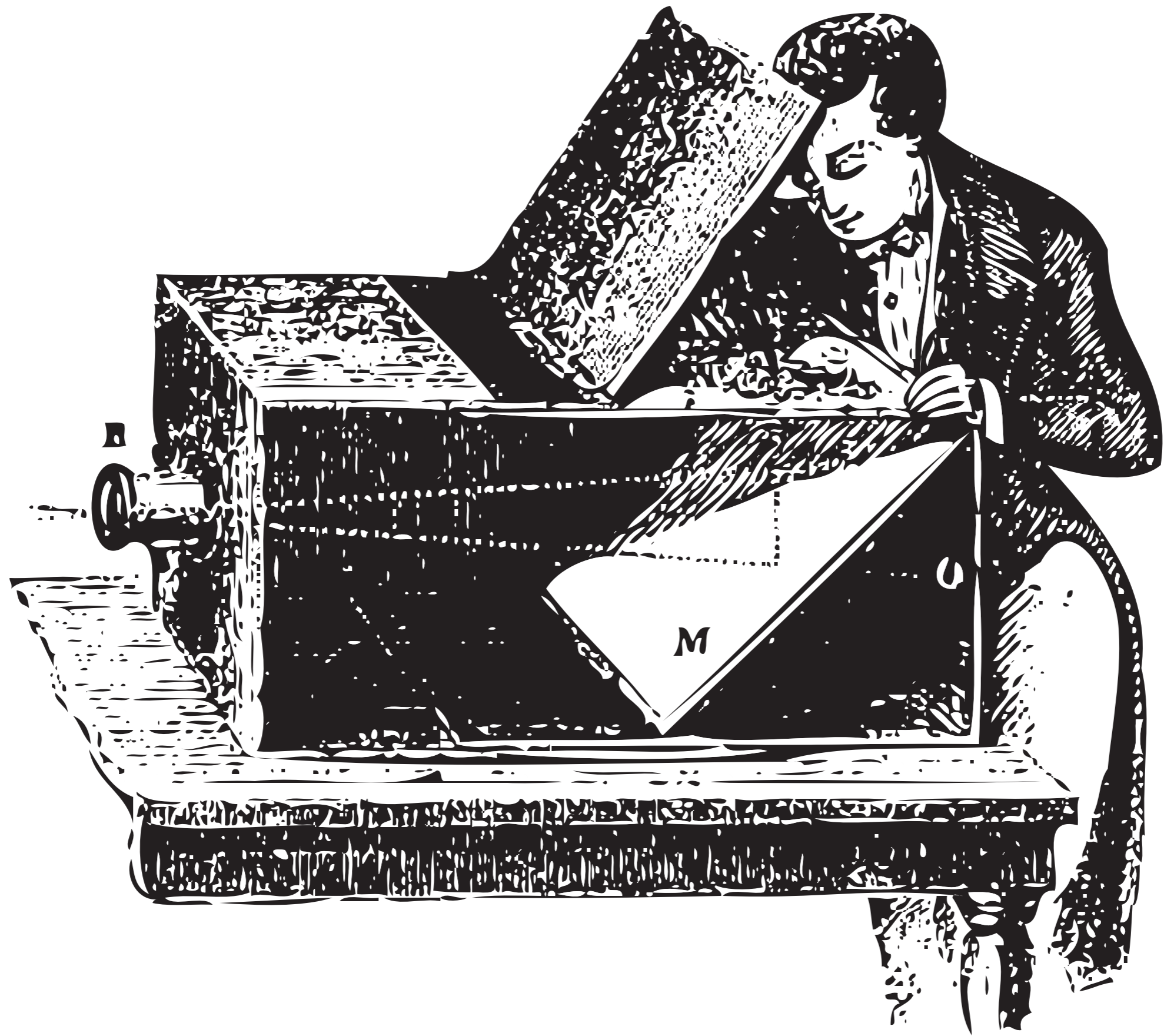

Thomas Wedgwood



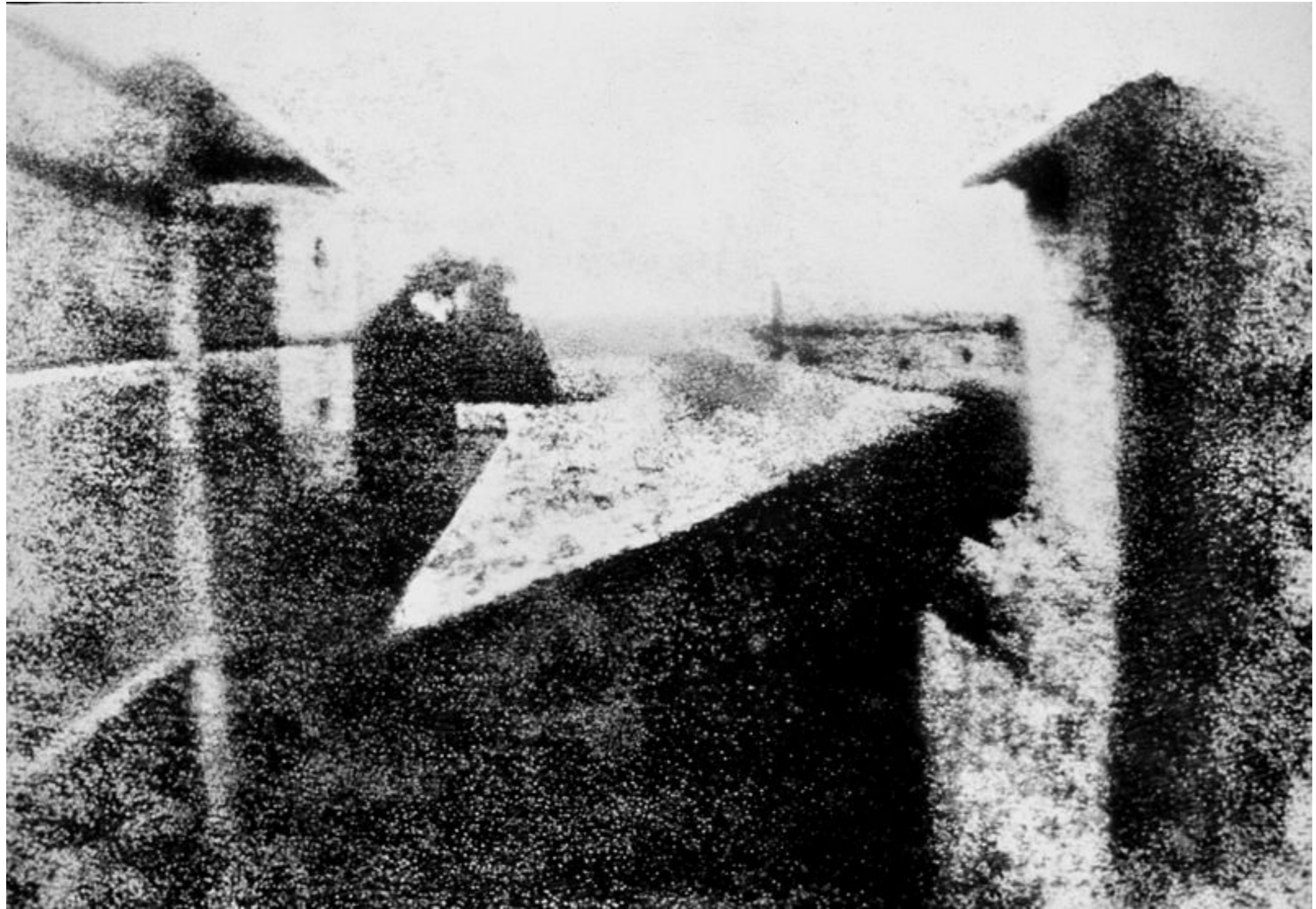

Joseph Nicéphore Niépce

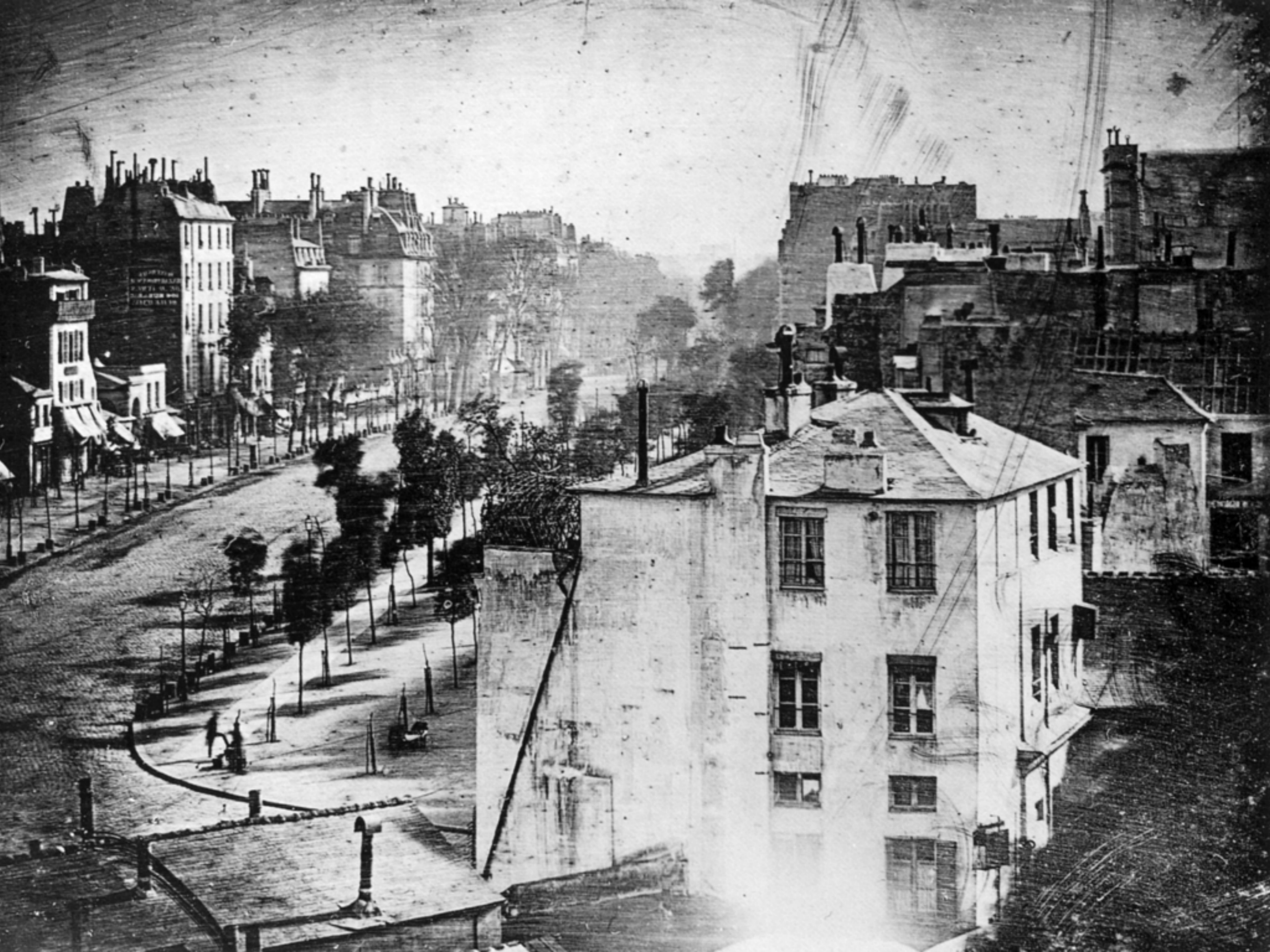







EASTMAN KODAK CO^S BROWNIE CAMERA \$1

The Brownie Camera

makes pictures 2 1/4 x 2 1/4 inches. Loads in daylight with our six exposure film cartridges, and is so simple that it can be easily

Operated by any School Boy or Girl.

Fitted with fine Meniscus lenses and our improved rotary shutter for snap shots or time exposures. Strongly made, covered with imitation leather, has nicked fittings and produces the best results.

Forty-four-page booklet giving full directions for operating the camera, together with chapters on "Snap Shots," "Time Exposures," "Flash Lights," "Developing" and "Printing," free with every instrument.

Brownie Camera, for 2 1/4 x 2 1/4 pictures . . .	\$1.00
Transparent-Film Cartridge, 6 exposures, 2 1/4 x 2 1/415
Paper-Film Cartridge, 6 exposures, 2 1/4 x 2 1/410
Brownie Developing and Printing Outfit75



THE BROWNIE CAMERA CLUB OF AMERICA

EVERY boy and girl under sixteen years of age should join the Brownie Camera Club of America. Fifty Kodaks, valued at over \$500.00, will be given to members of the club as prizes for the best pictures made with the Brownie Cameras, and every member of the club will be given a copy of our Photographic Art Brochure. No initiation fees or dues if you own a Brownie. Ask your dealer or write us for a Brownie Camera Club Constitution.

Send a dollar to your local Kodak dealer for a Brownie Camera. If there is no Kodak dealer in your town, send us a dollar and we will ship the camera promptly.



Eastman Kodak Co., Rochester, N.Y.









Nikon

HP

3

KODAK Professional
DCS
DIGITAL CAMERA SYSTEM





Les Horribles Cernettes



1992

in 1960 **600,000** color photos existed

in 1974 **103 million** color photos existed

5 billion+ photos on Flickr

2.5 billion photos per *month* uploaded to Facebook

30 billion per year

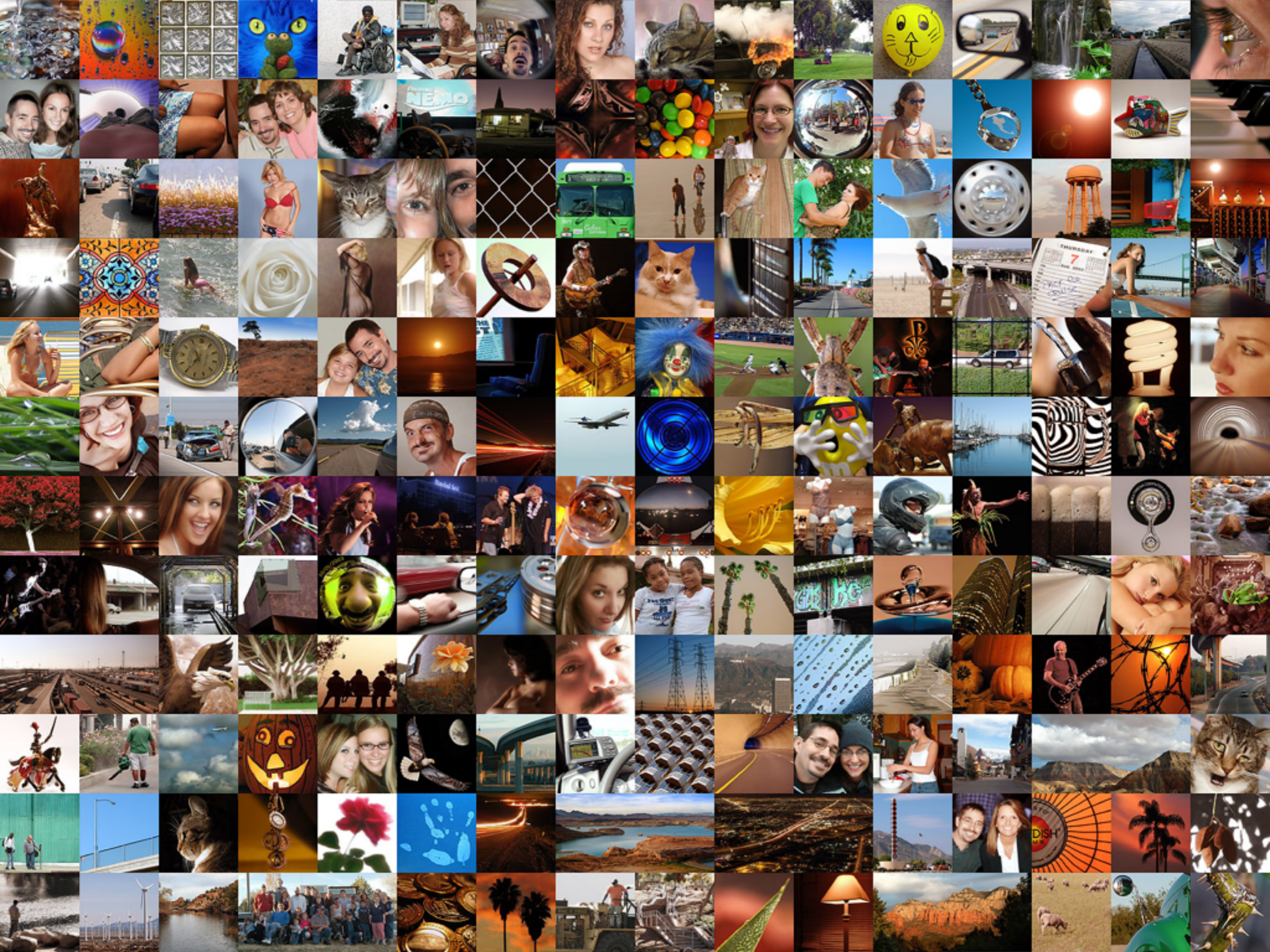

Exposure.



← over exposure

under exposure →

Shutter Speed

Controlling light with time.

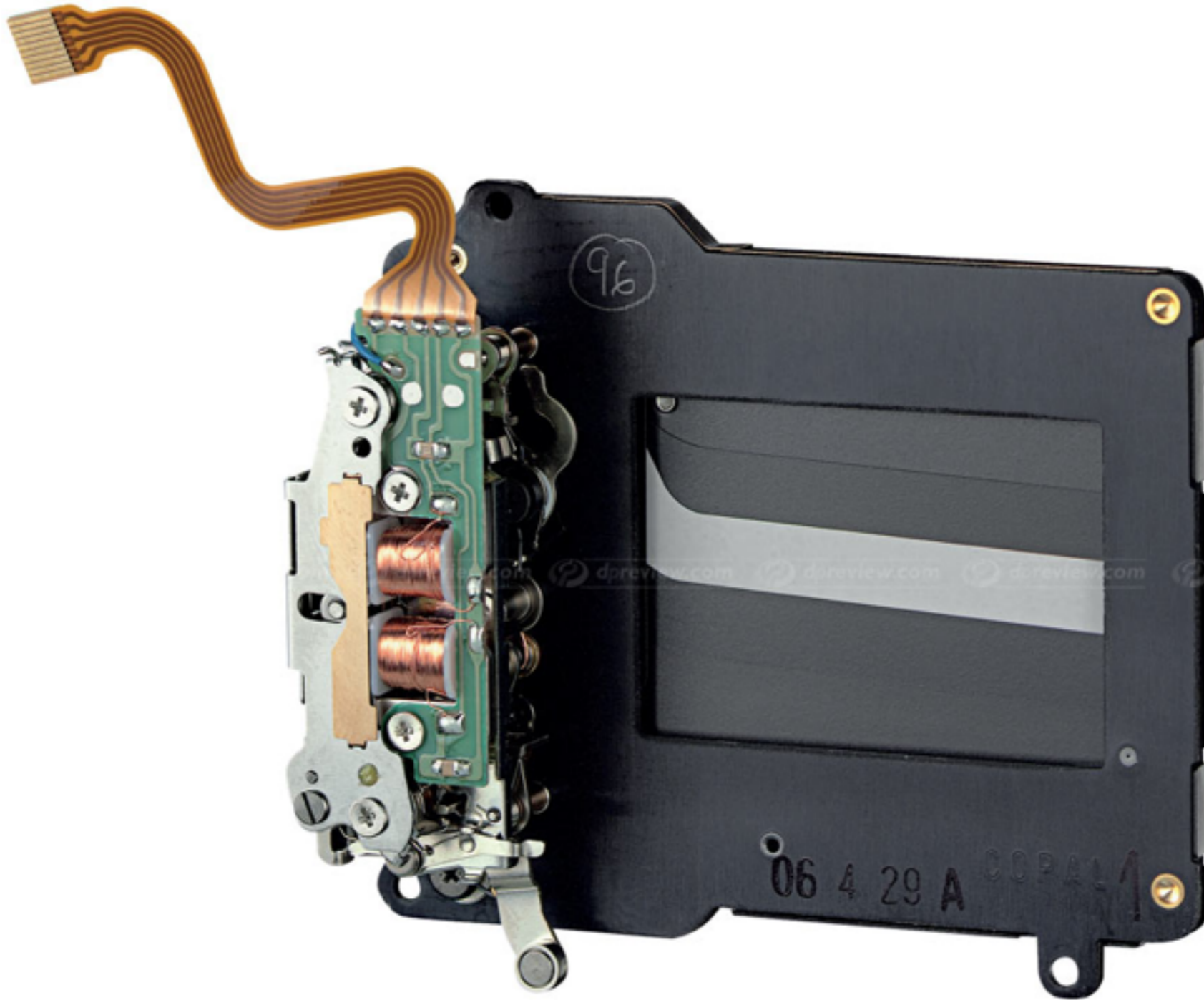

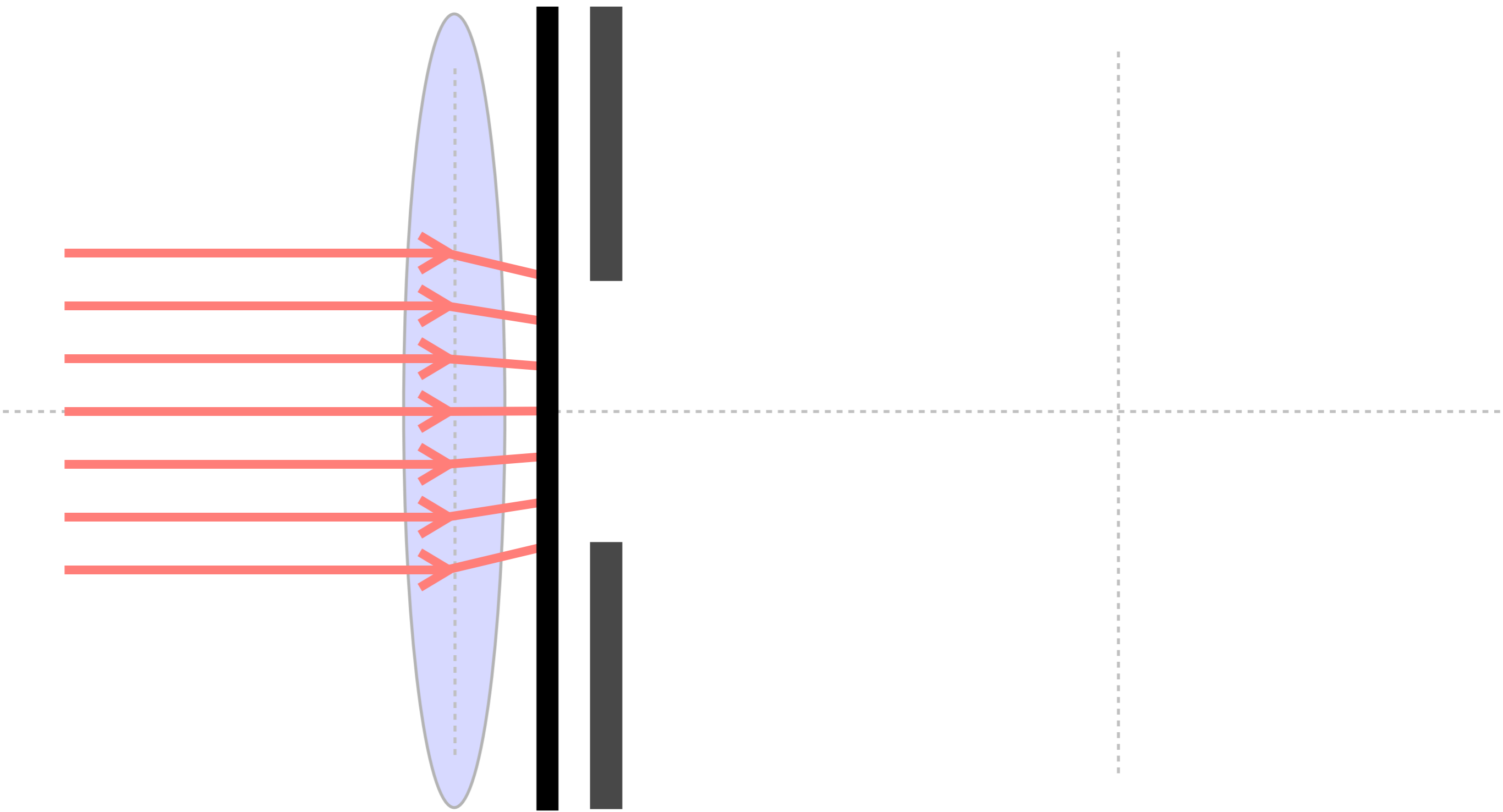

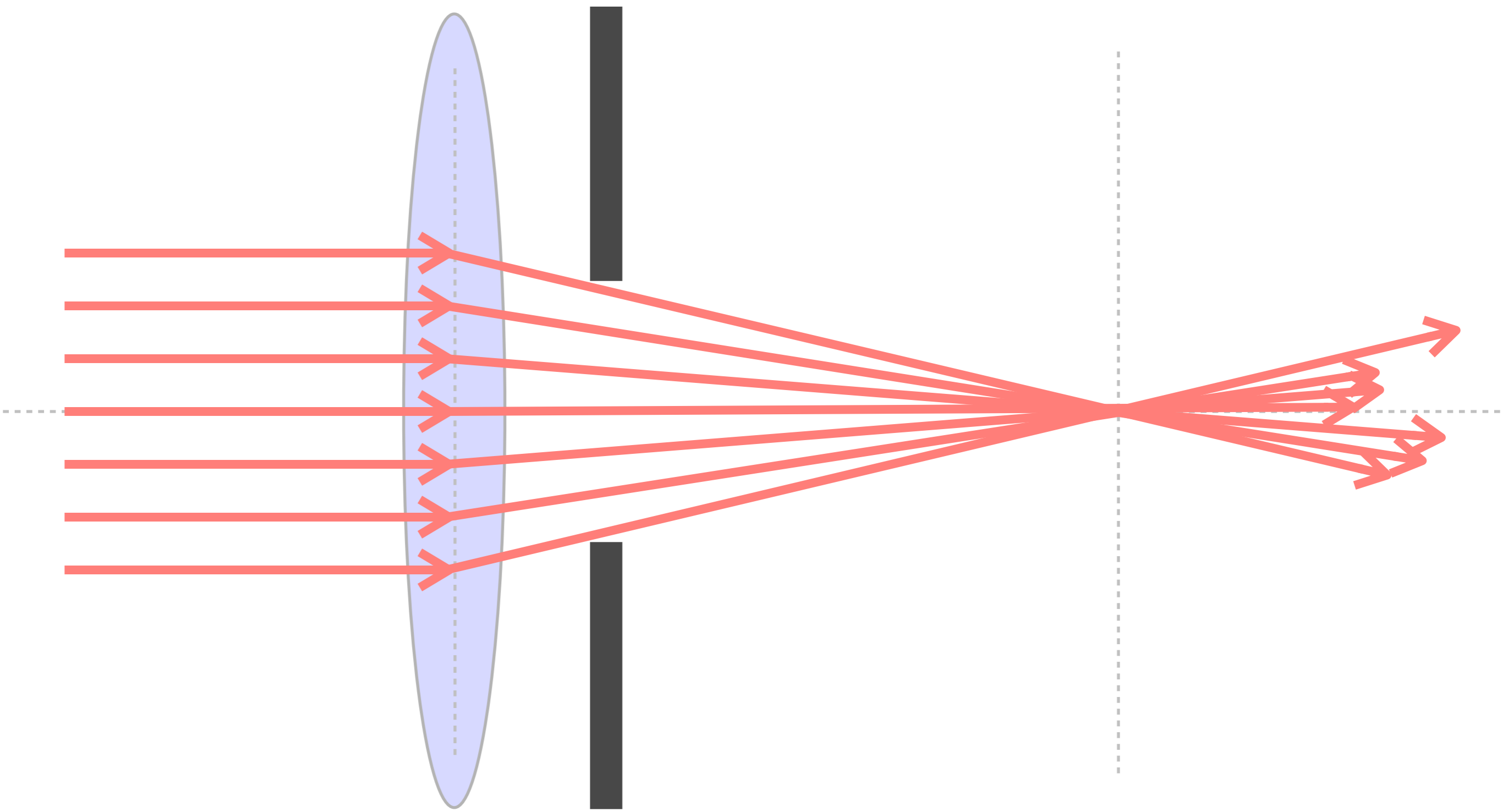

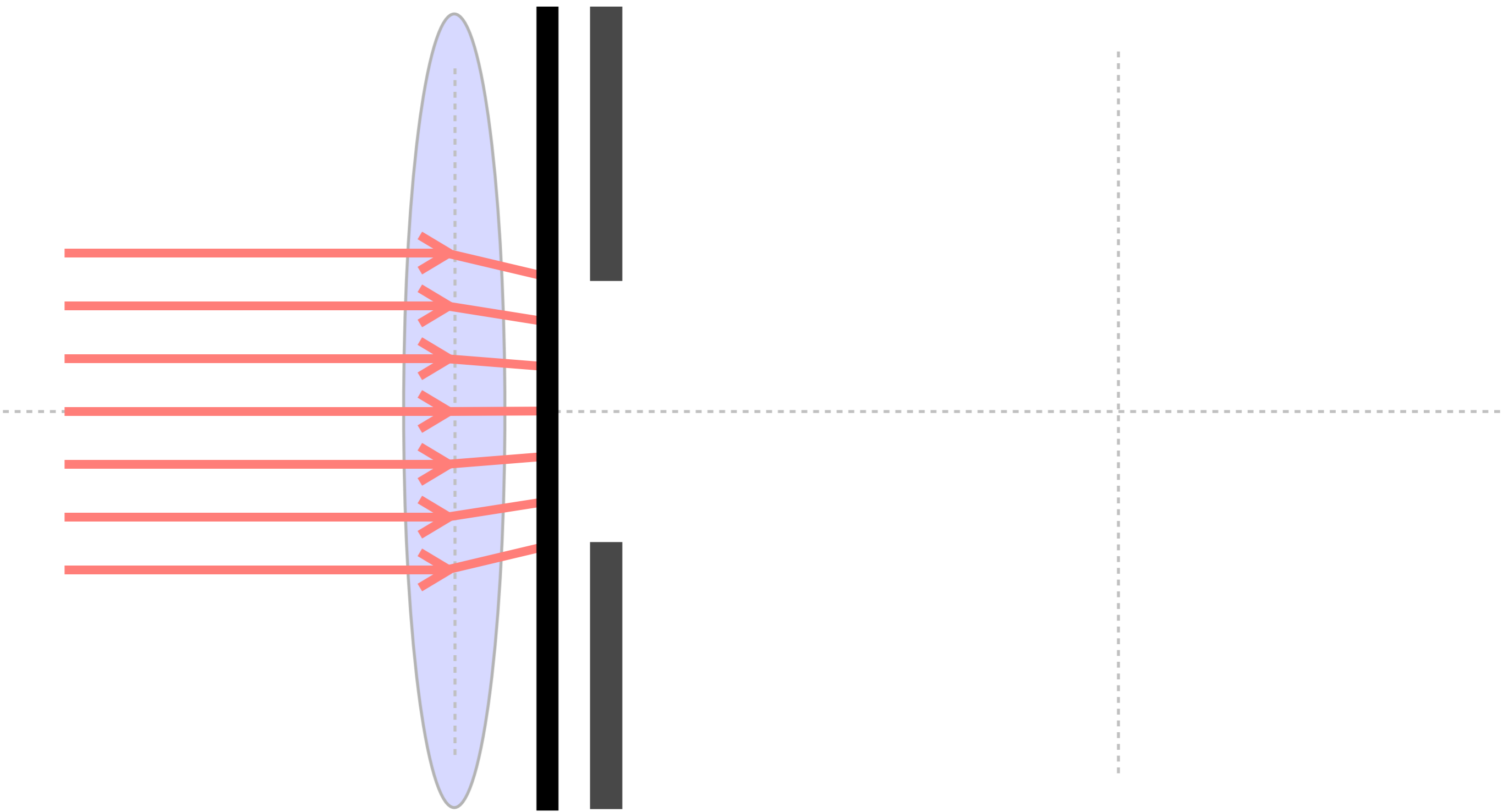

$1/1000 \text{ s}$

$1/500 \text{ s}$

$1/250 \text{ s}$

$1/125 \text{ s}$

$1/60 \text{ s}$

$1/30 \text{ s}$

$1/15 \text{ s}$

$1/8 \text{ s}$

$1/4 \text{ s}$

$1/2 \text{ s}$

1 s

1/1000 s

1/500 s

1/250 s

1/125 s

1/60 s

1/30 s

1/15 s

1/8 s

1/4 s

1/2 s

1 s

1/1000 s

1/500 s

1/250 s

1/125 s

1/60 s

1/30 s

1/15 s

1/8 s

1/4 s

1/2 s

1 s

Aperture
Controlling light with size.



f/2

Aperture
Controlling light with size.



f/2.8

Aperture
Controlling light with size.



f/4

Aperture
Controlling light with size.



f/5.6

Aperture

Controlling light with size.



f/8

Aperture

Controlling light with size.



f/22

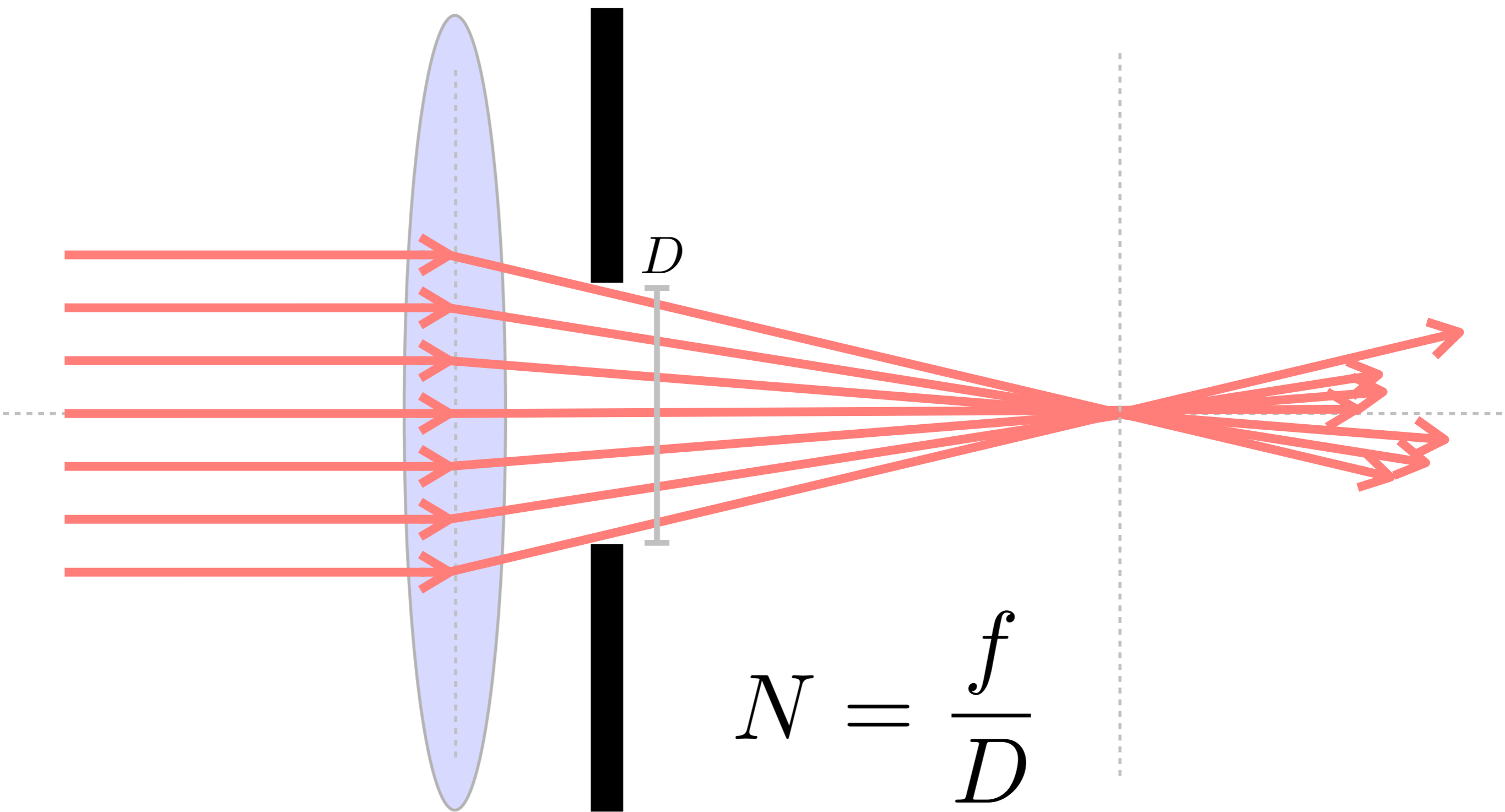

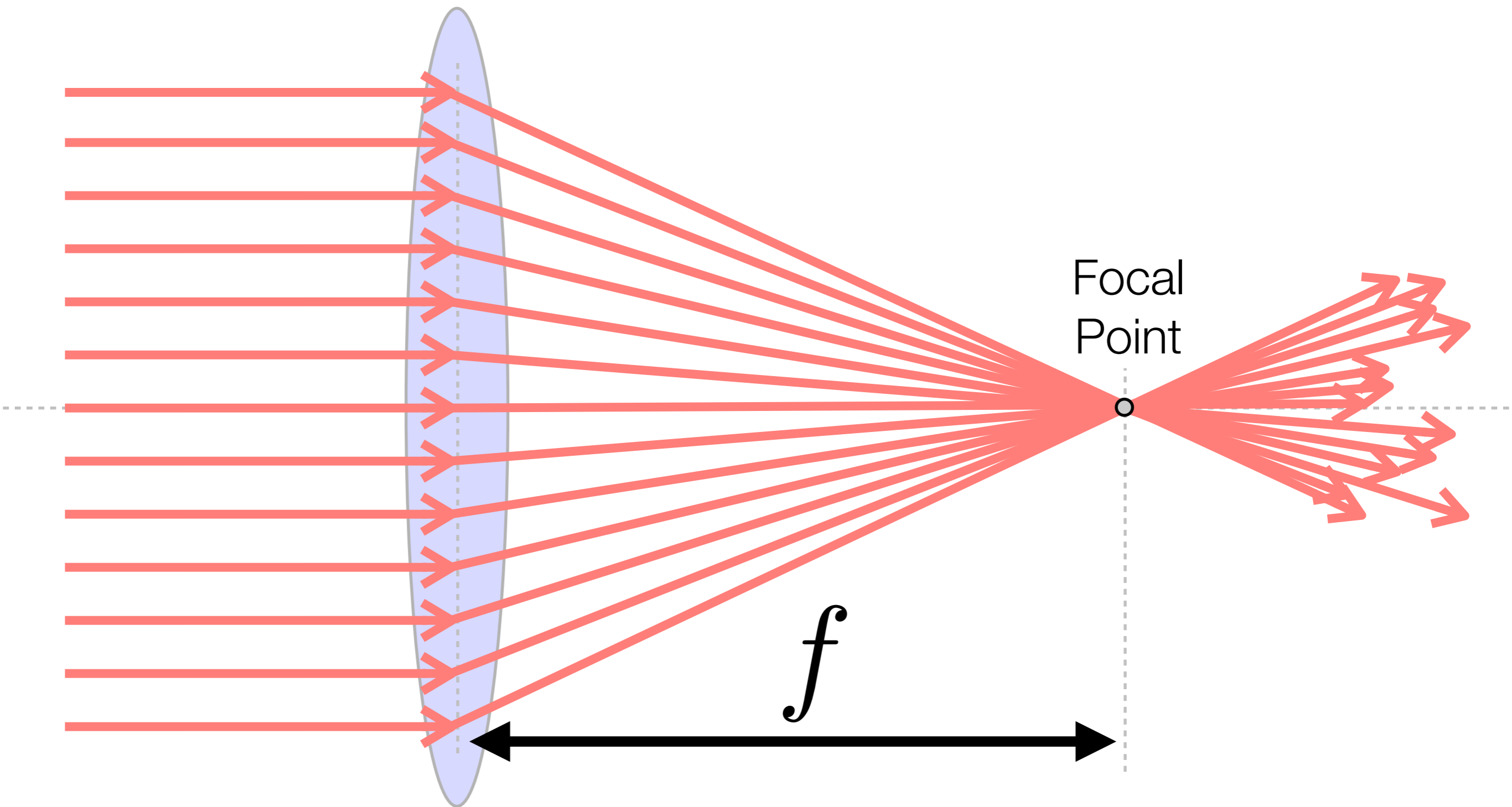

$$N = \frac{f}{D} \quad \text{or, typically...} \quad D = \frac{f}{N}$$

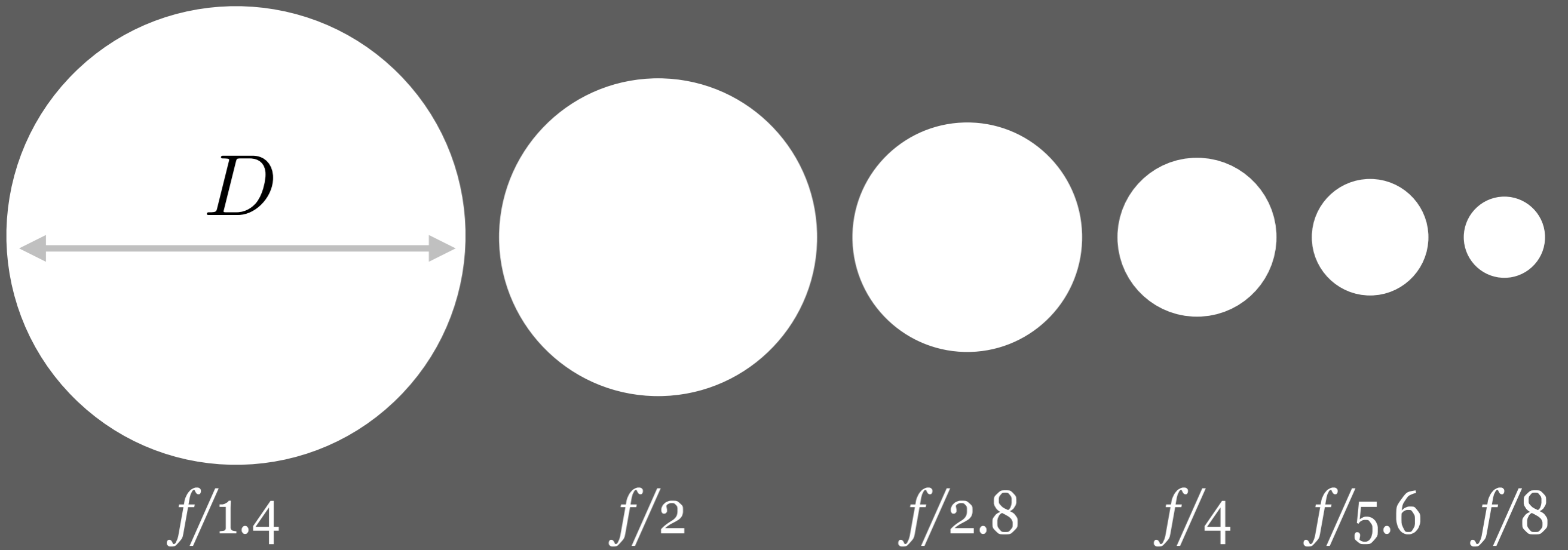

Aperture + Shutter Speed

A relationship of stops.



f/2

1/1000 s

Aperture + Shutter Speed

A relationship of stops.



f/2.8
1/2 light

1/500 s
2x time

Aperture + Shutter Speed

A relationship of stops.



f/4 **1/250 s**
(1/2)² light 2²x time

Aperture + Shutter Speed

A relationship of stops.



f/5.6 **1/125 s**
 $(1/2)^3$ light 2^3 x time

Aperture + Shutter Speed

A relationship of stops.



f/8 **1/60 s**
(1/2)⁴ light ~2⁴ x time

ISO



CCD

ISO is essentially hardware gain.

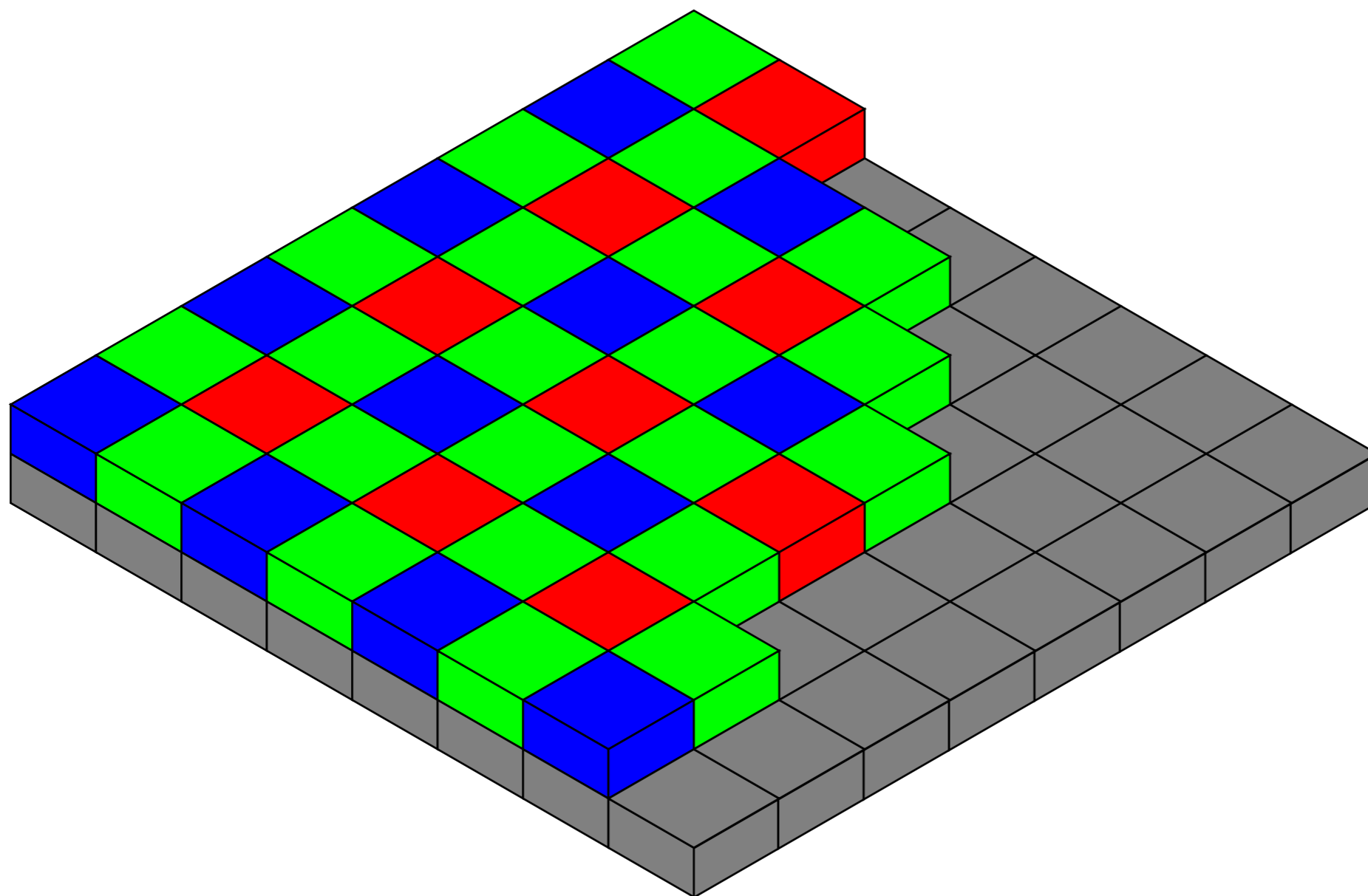

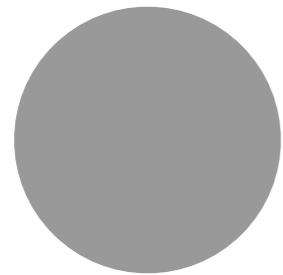

200 ISO

- Daylight
- Bright, bright studio lighting

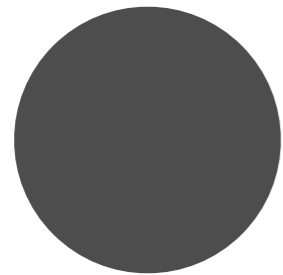

400-1600 ISO

- Outdoors, action shots
- Indoors, adequate lighting
- Shade

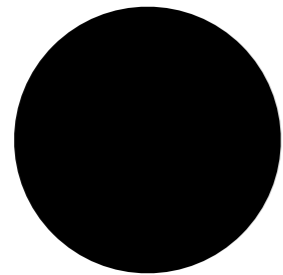

3200+ ISO

- Indoors, poor lighting
- Indoors, action shots
- Night time (+ some software gain)

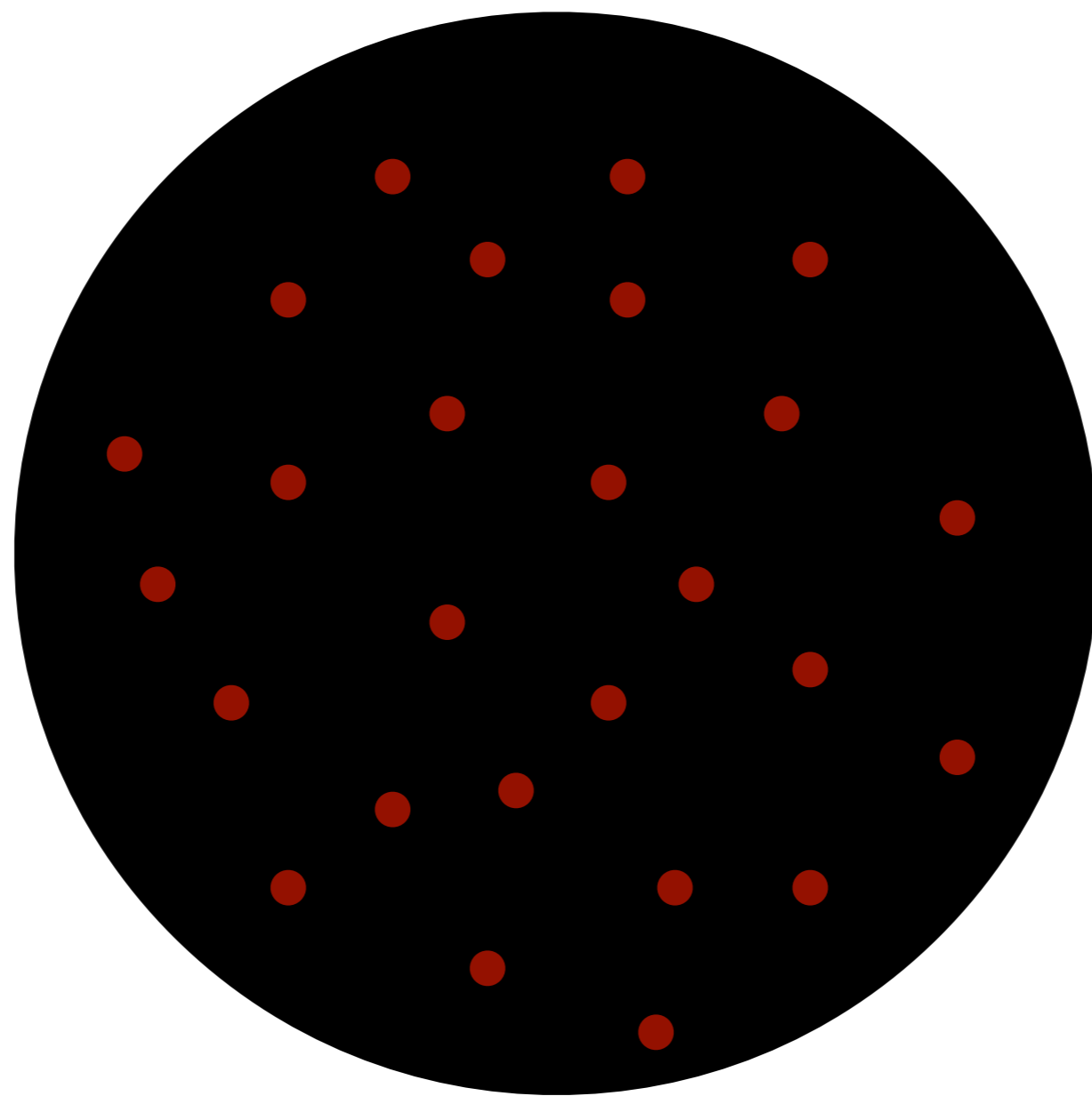



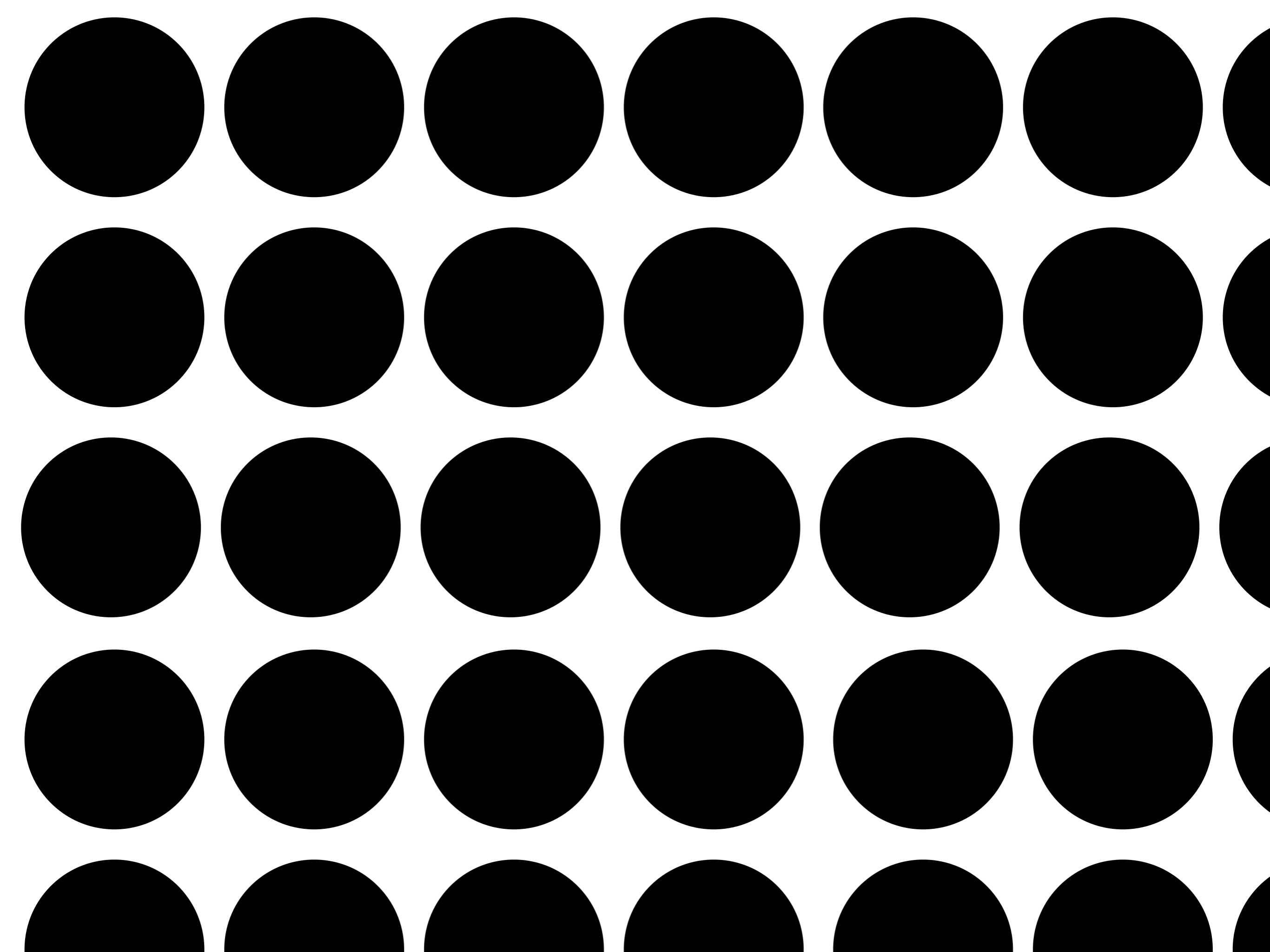

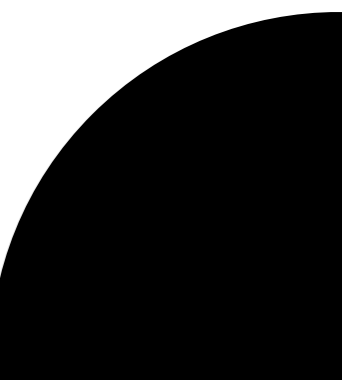
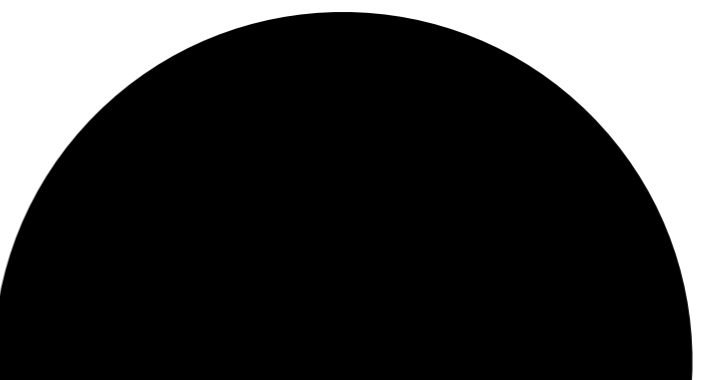
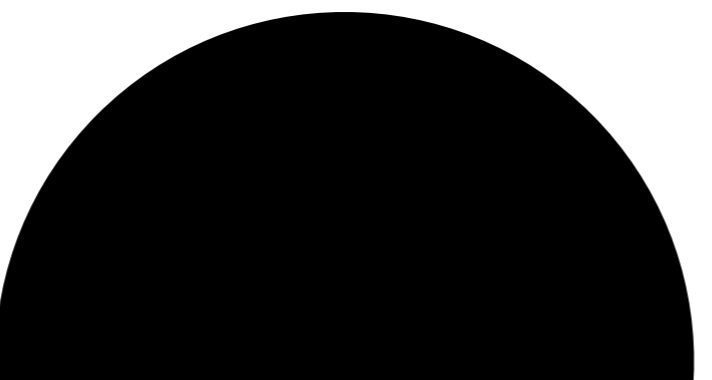
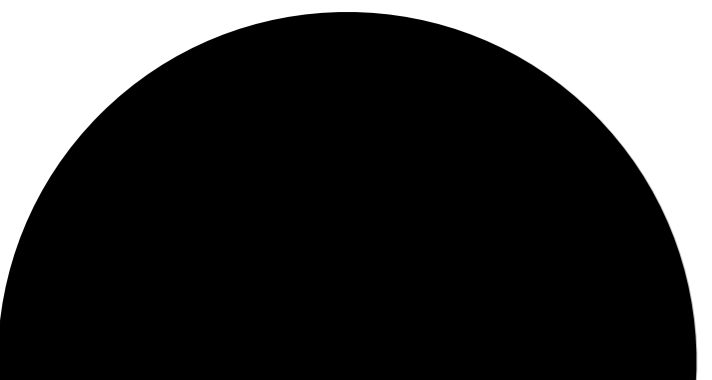
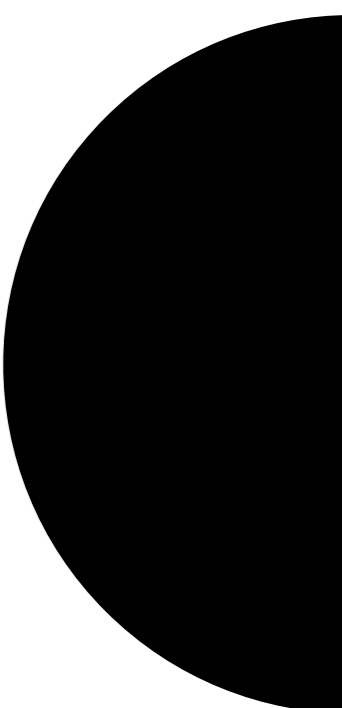
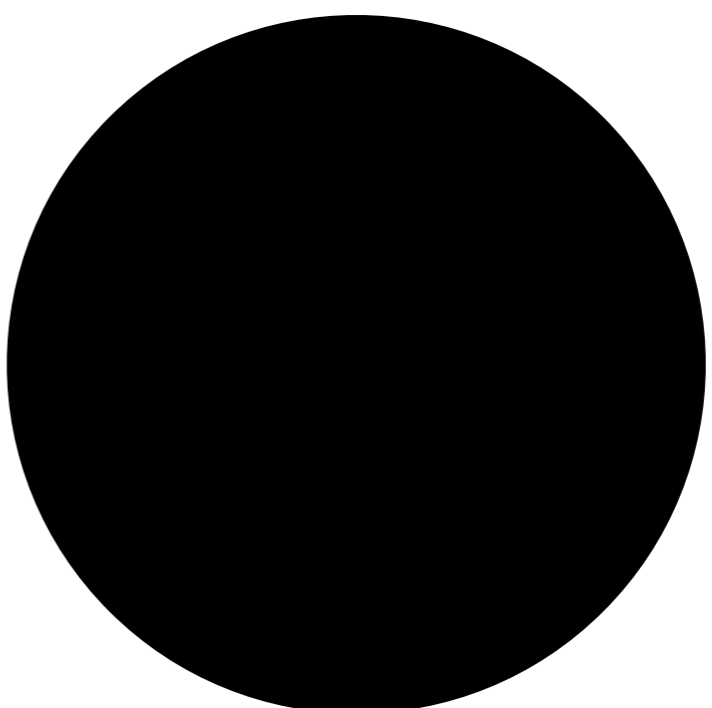
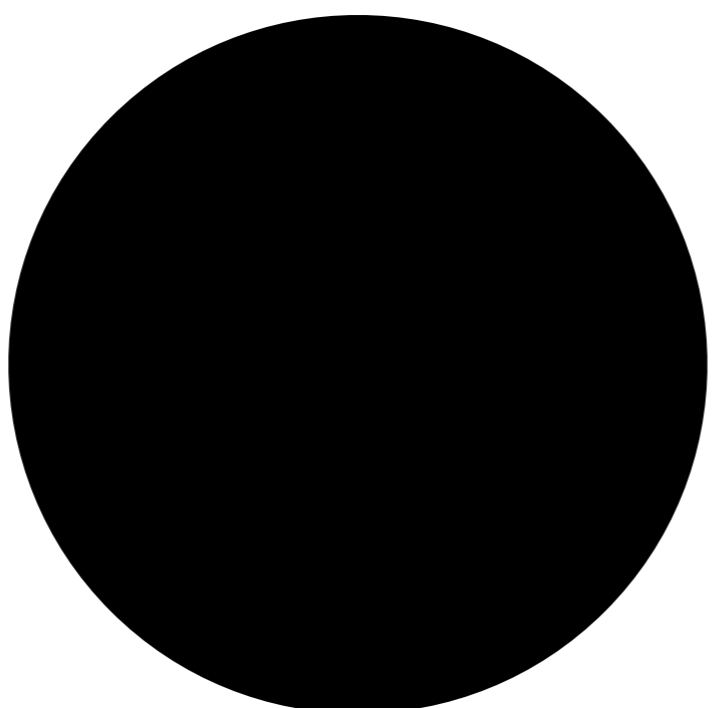
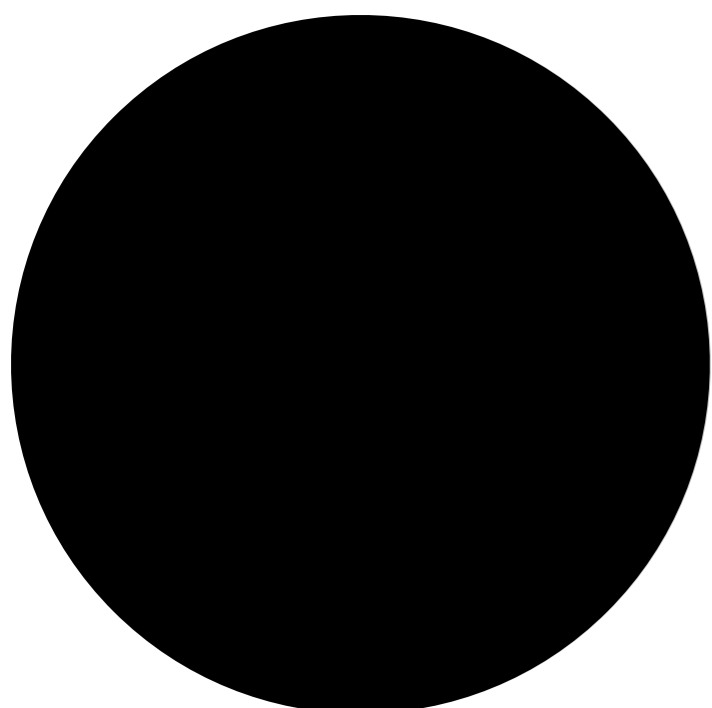
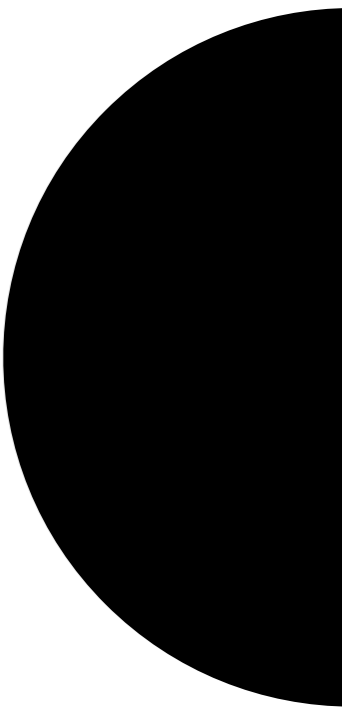
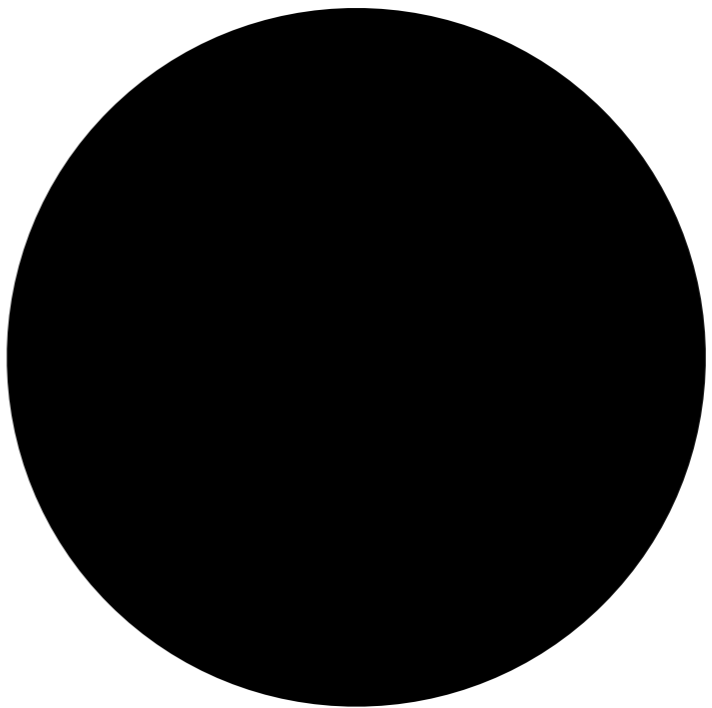
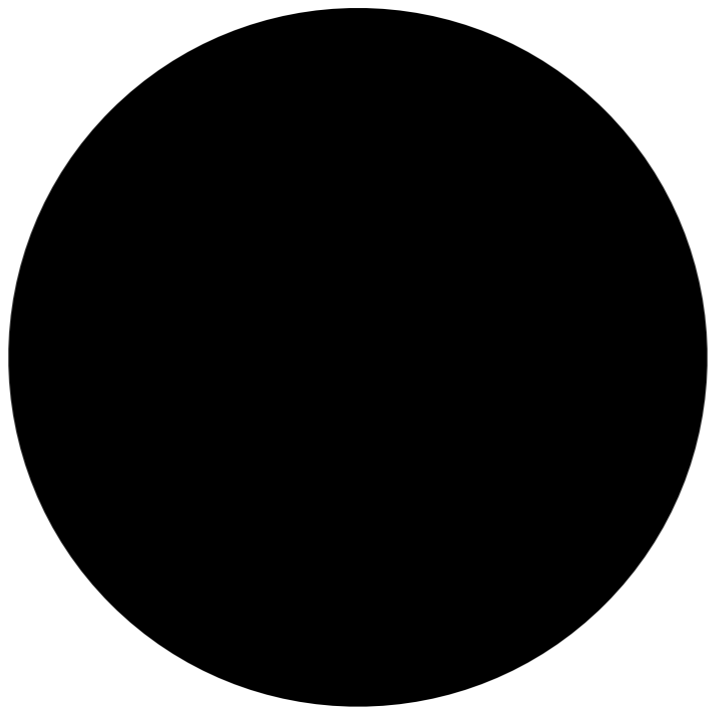
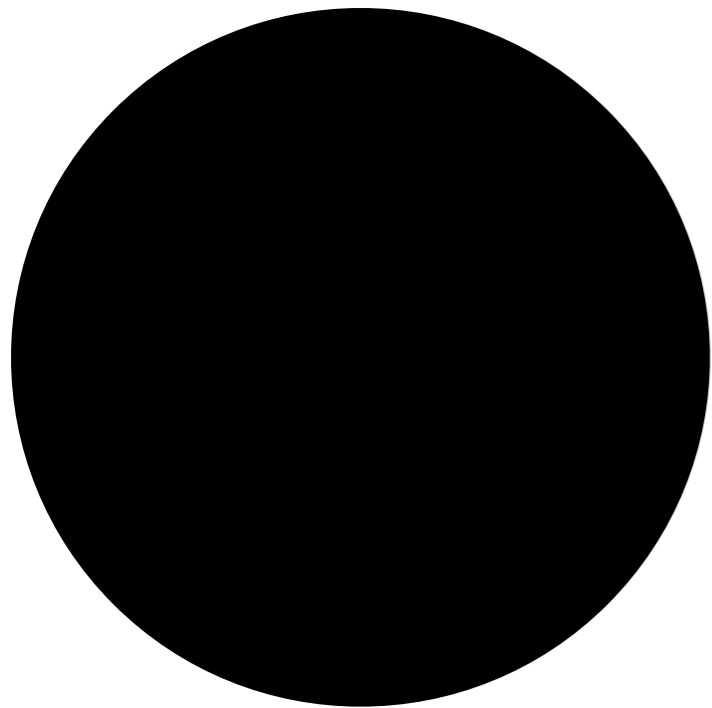

1st tool in composition:

Depth of Field.

Narrow Depth of Field

Large aperture, small f-number ($f/1.8$).



Irving Penn

Wide Depth of Field
Small aperture, large f-number ($f/64$).



Ansel Adams

A little less in focus, but not noticeable

Noticeably out of focus

In focus

Circle of Confusion

Depth of Field

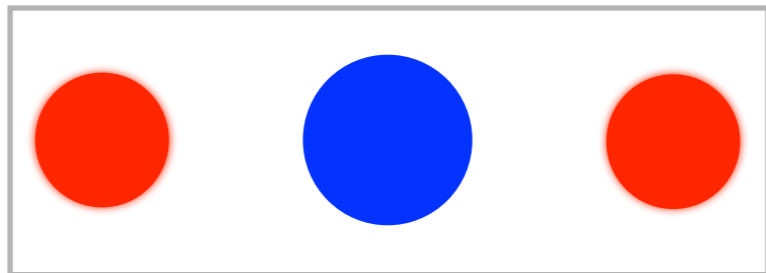
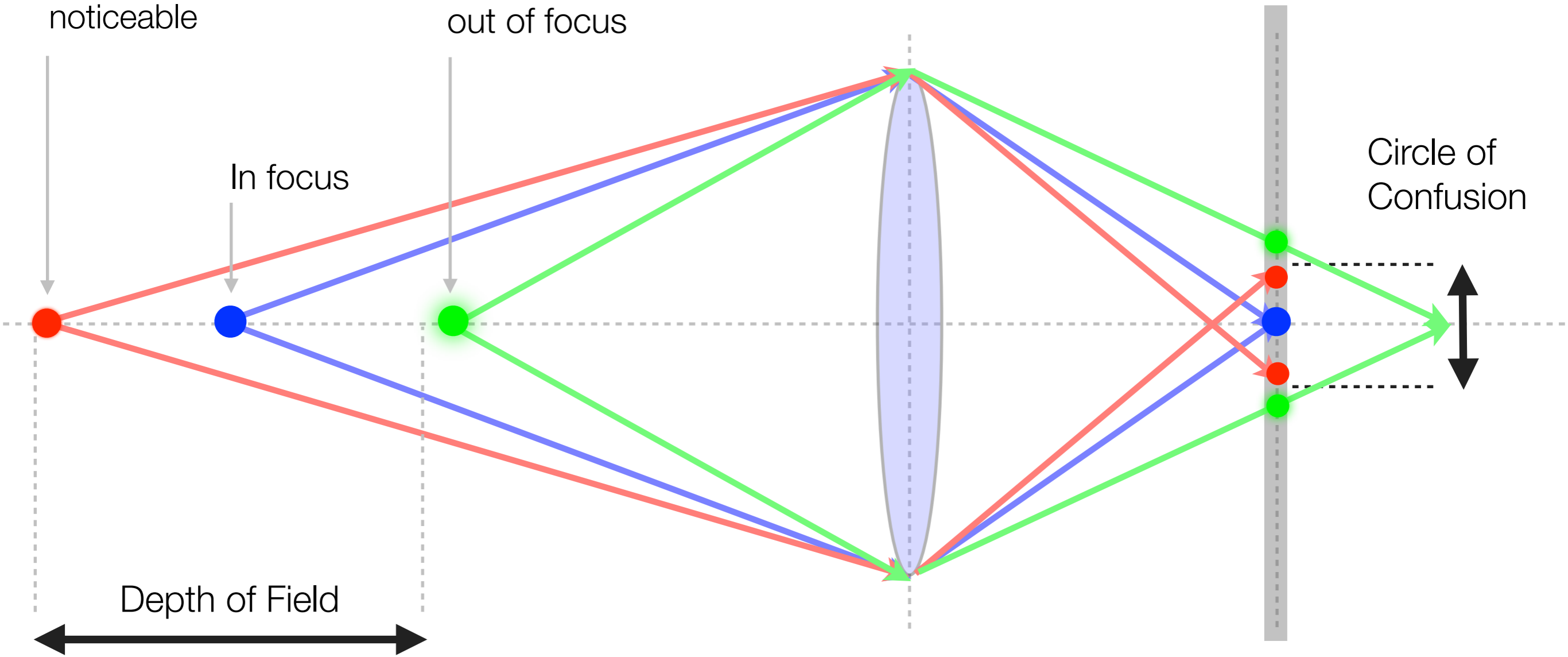

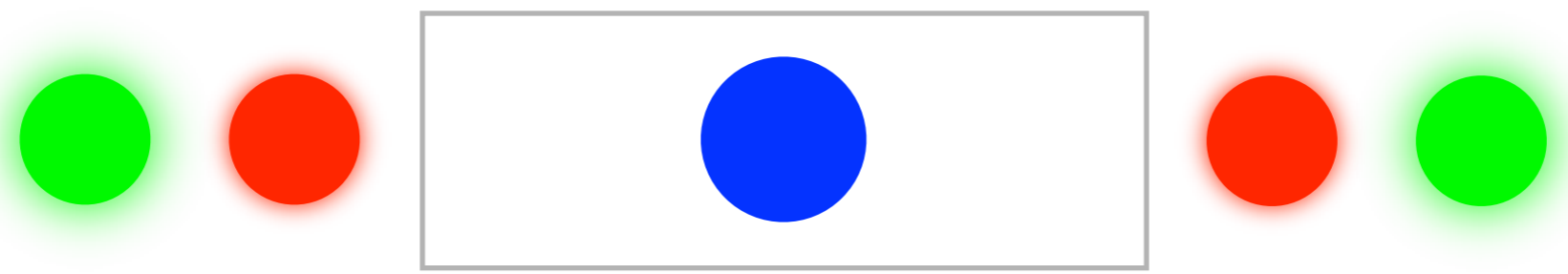
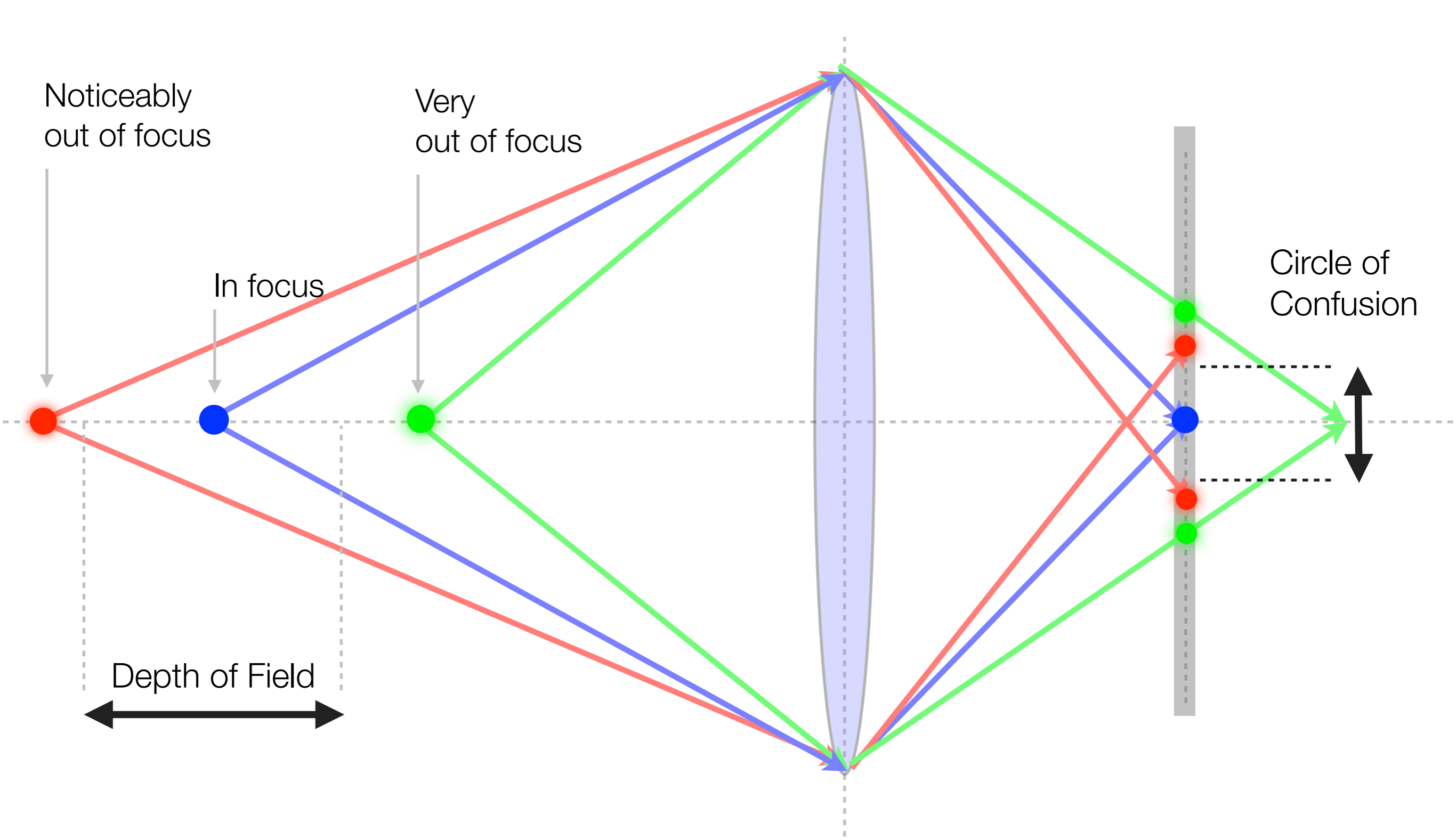



Assignment:

- long exposure
- action shot (short exposure)
- narrow depth of field
- wide depth of field

email by Saturday evening

Focal Length



200 mm



50 mm



28 mm



14 mm



135 mm



85 mm

Angle of View

Angle of View

A wide lens (short focal length).

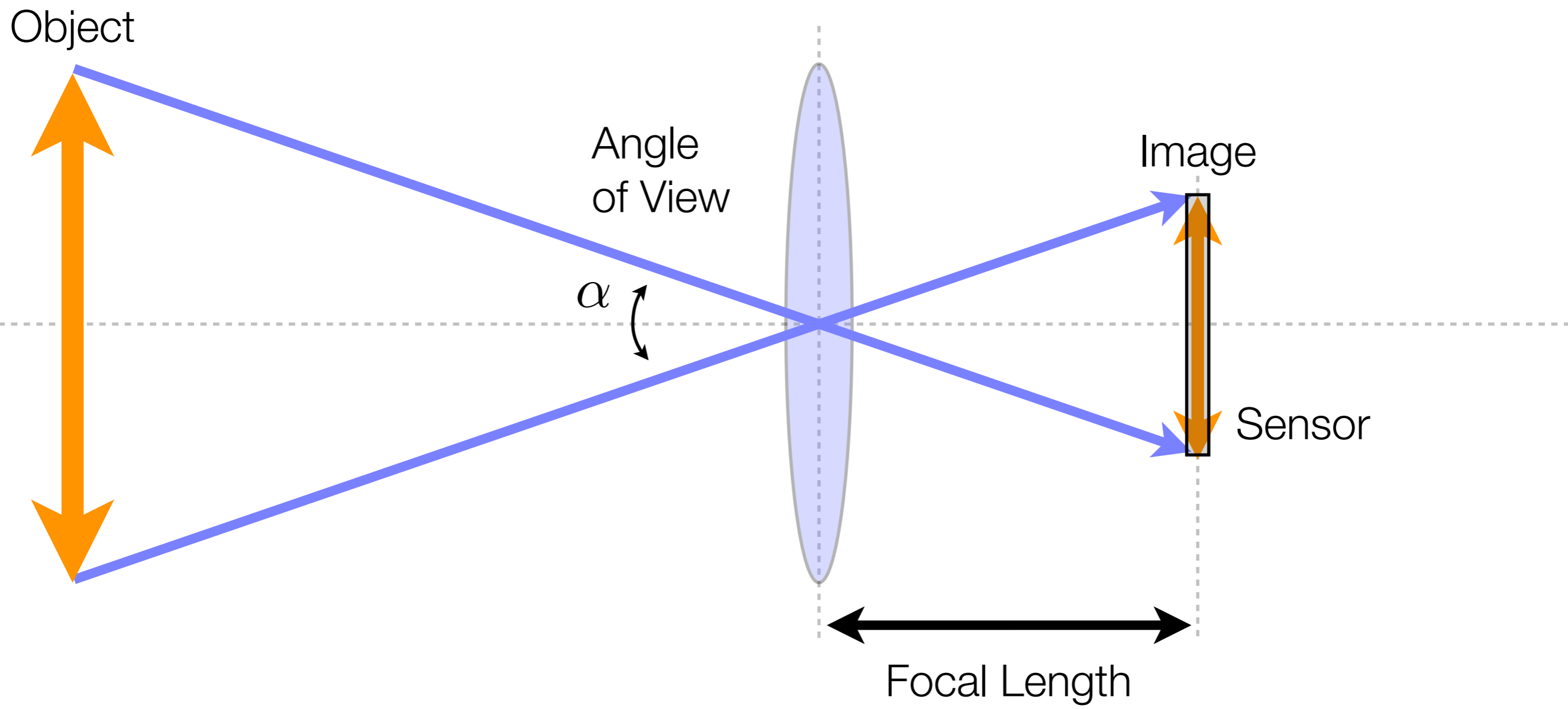

Angle of View

A long lens (long focal length).

Object

Image

Angle
of View

α

Sensor

Focal Length

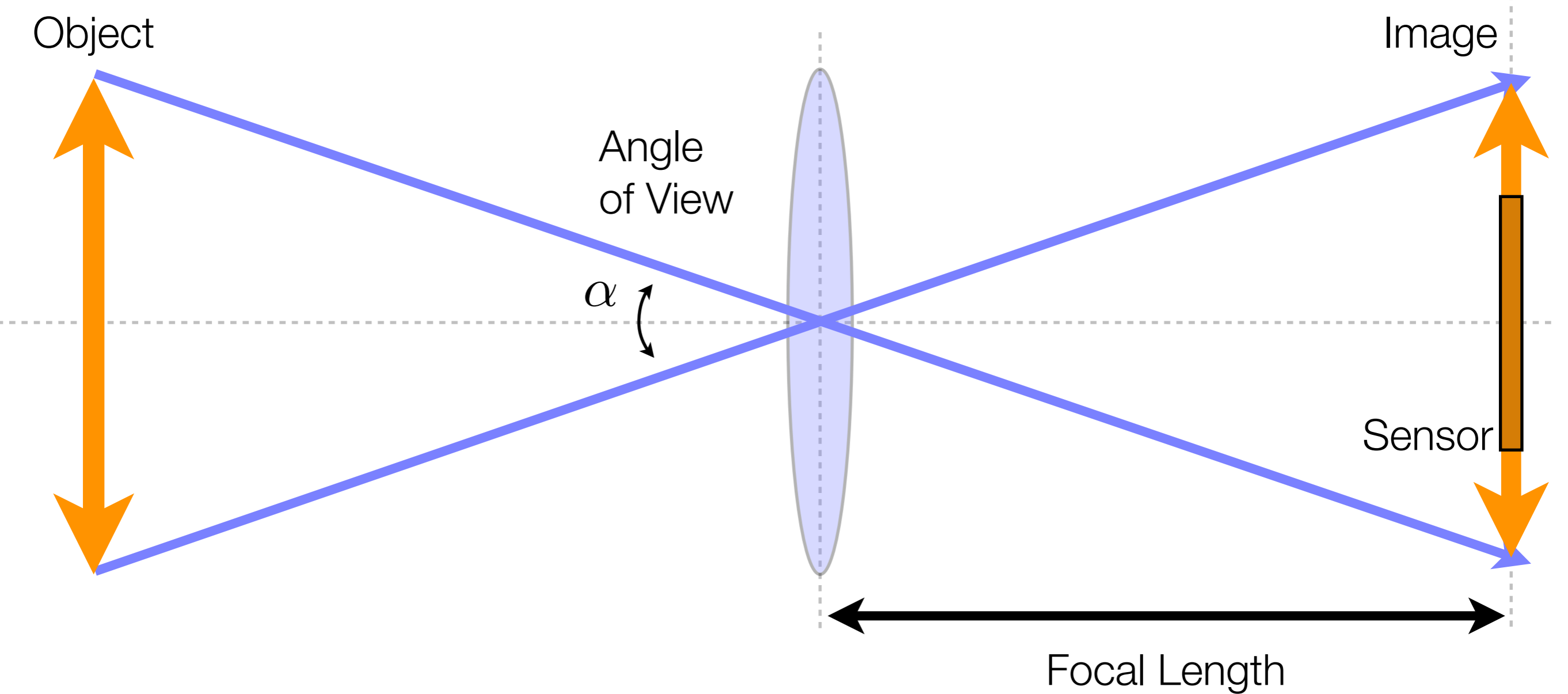

Basic Nikon dSLR info screen.

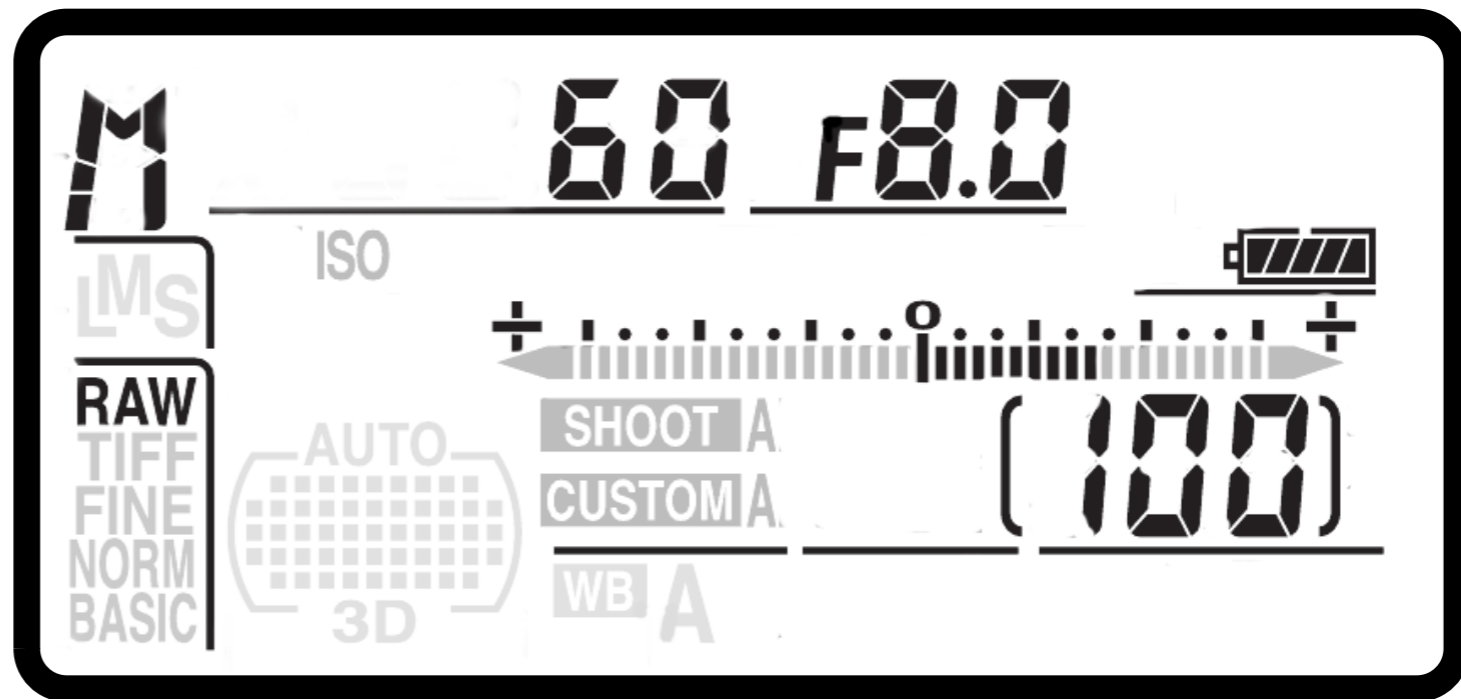

Shooting Mode



M **60** **F8.0**

LMS ISO 

RAW  **SHOOT A** **(100)**

TIFF **AUTO** **CUSTOM A**

FINE  **WB A**

NORM **3D**

BASIC



Shooting Mode

Shutter Speed

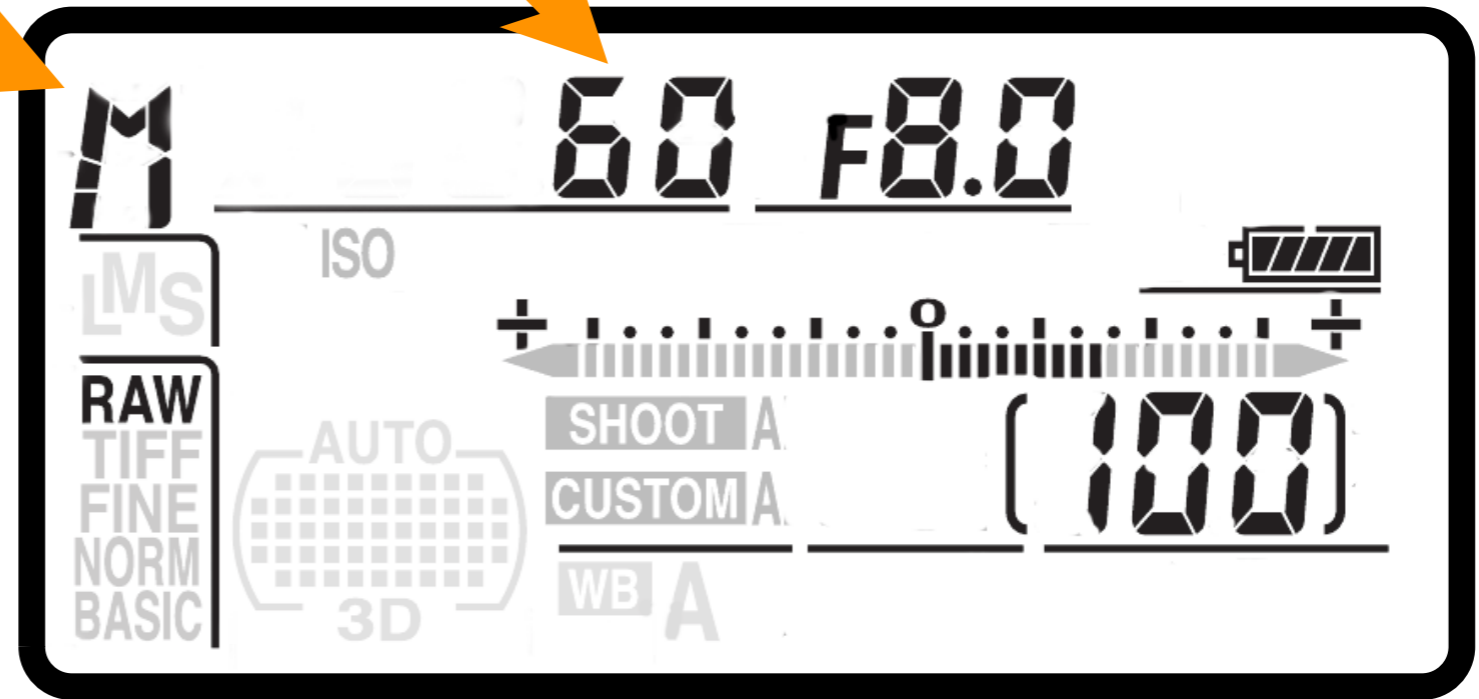



Shooting Mode

Shutter Speed

F-Number

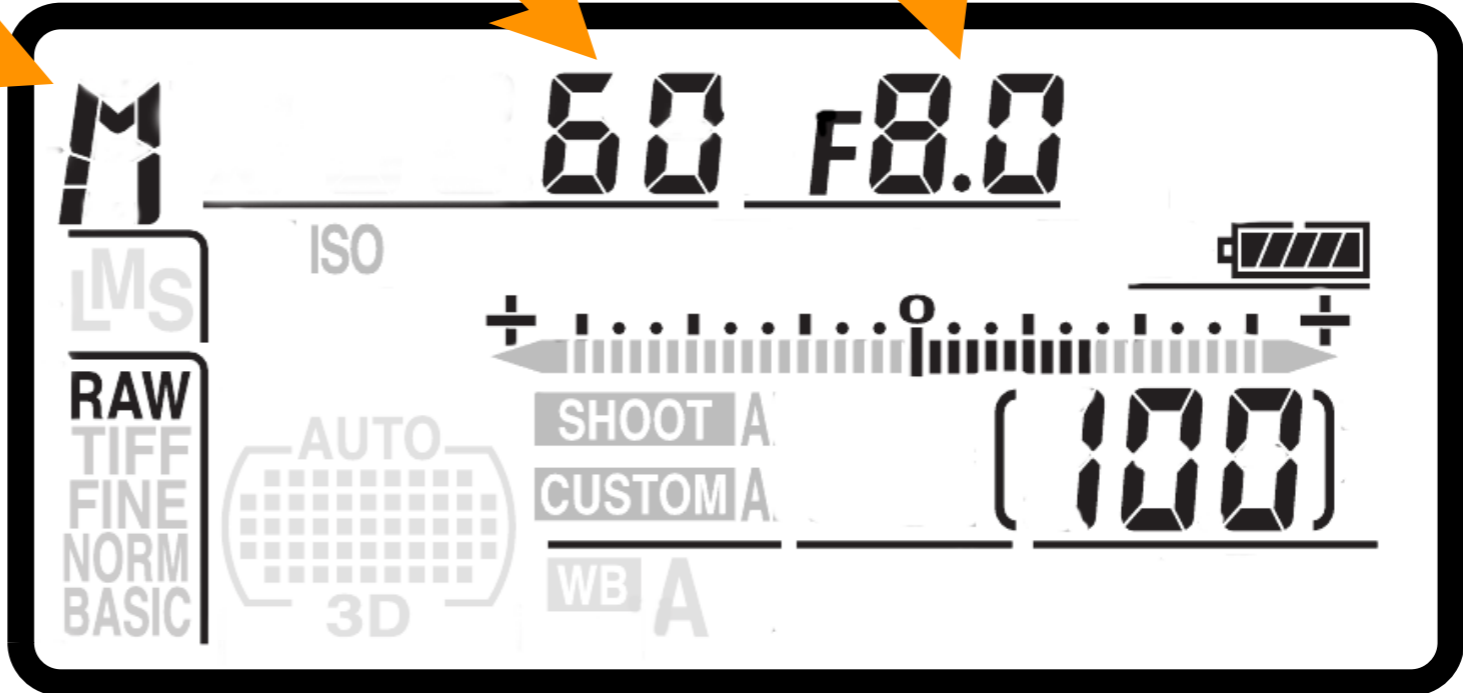



Shooting Mode

Shutter Speed

F-Number

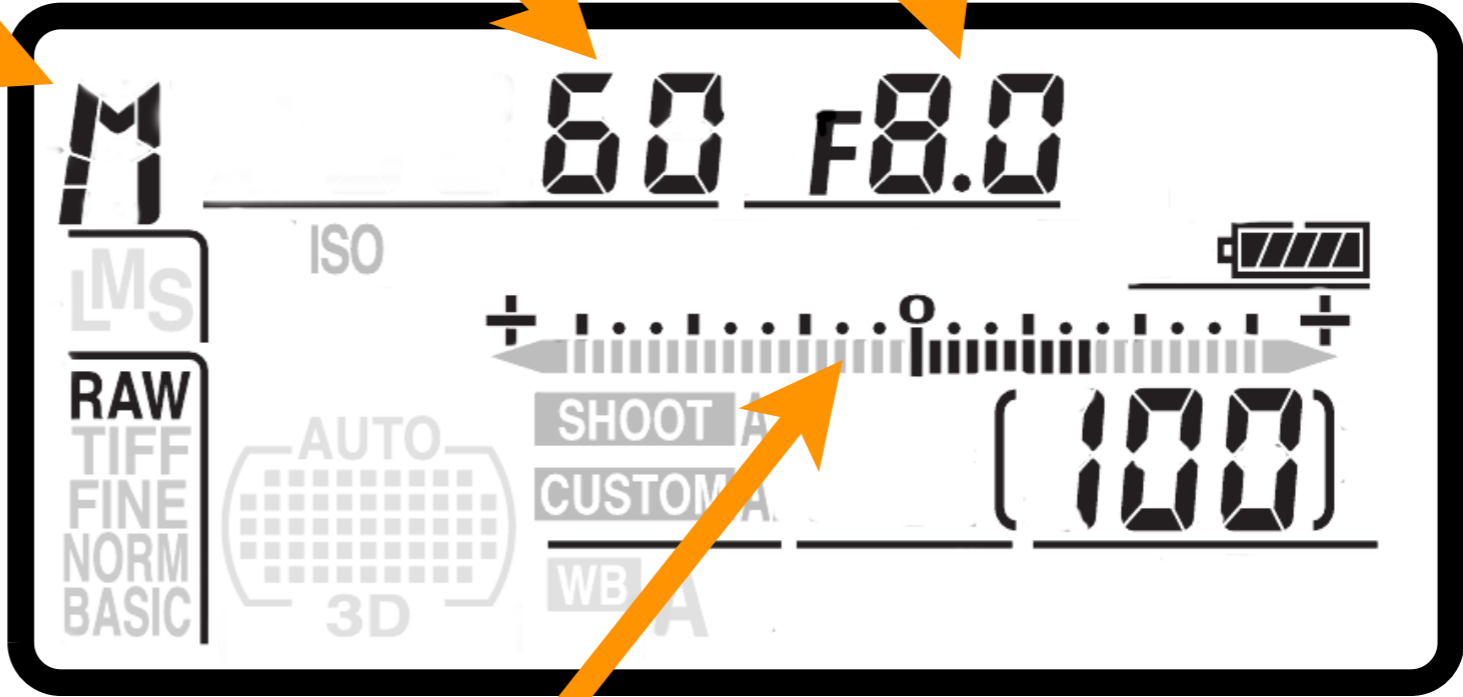

Exposure Meter

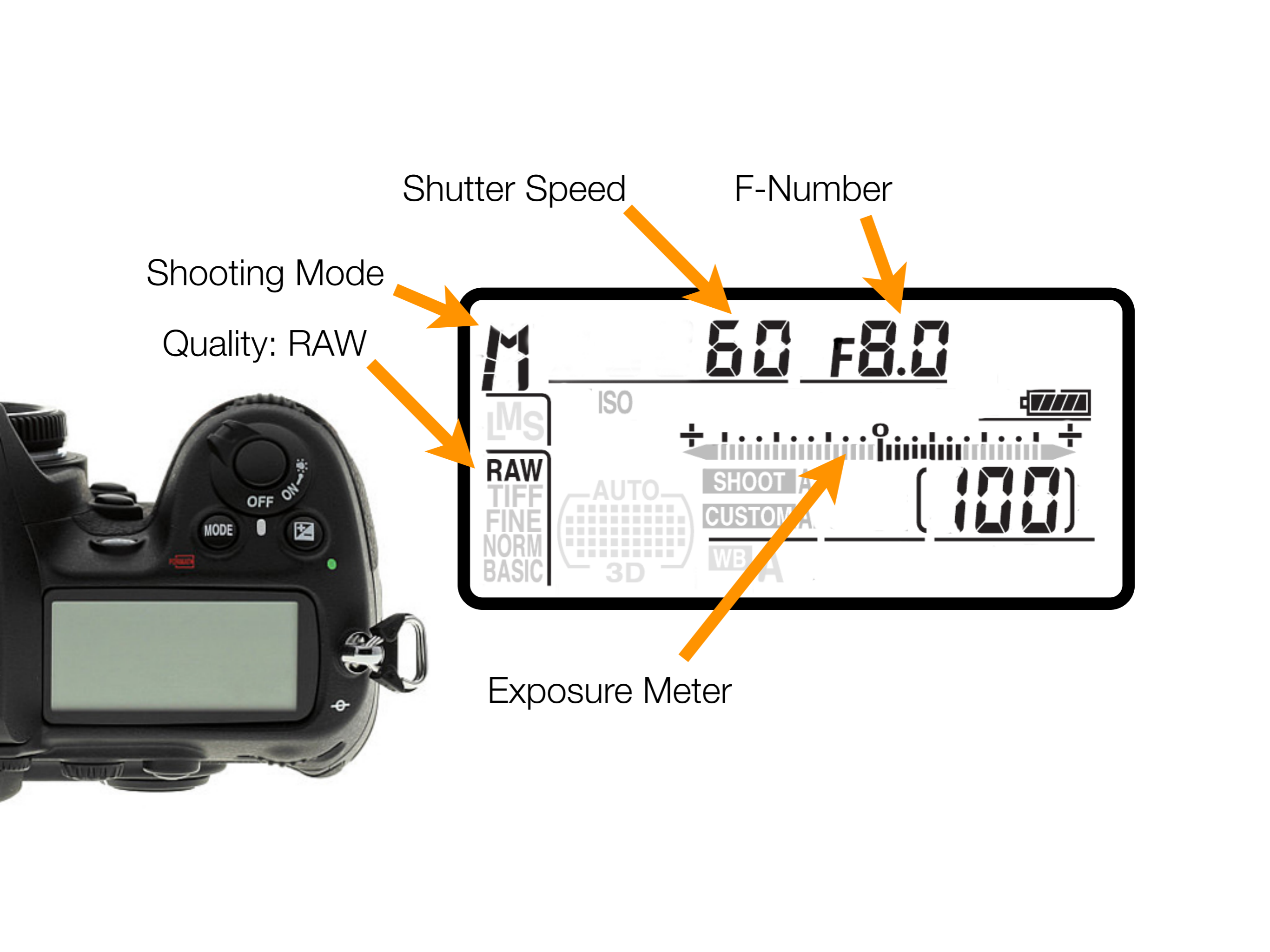

Shutter Speed

F-Number

Shooting Mode

Quality: RAW

Exposure Meter

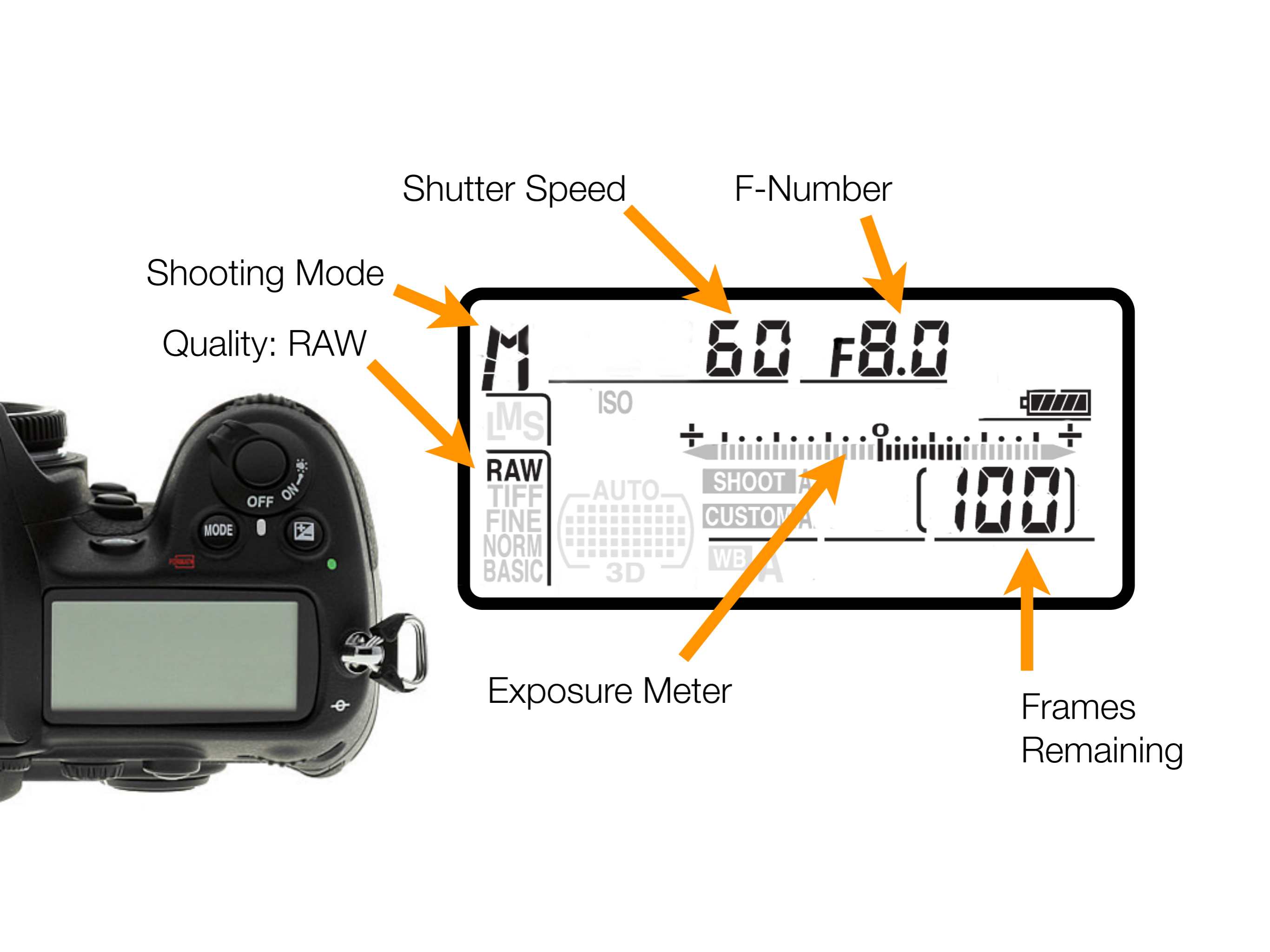

Shutter Speed

F-Number

Shooting Mode

Quality: RAW

Exposure Meter

Frames Remaining

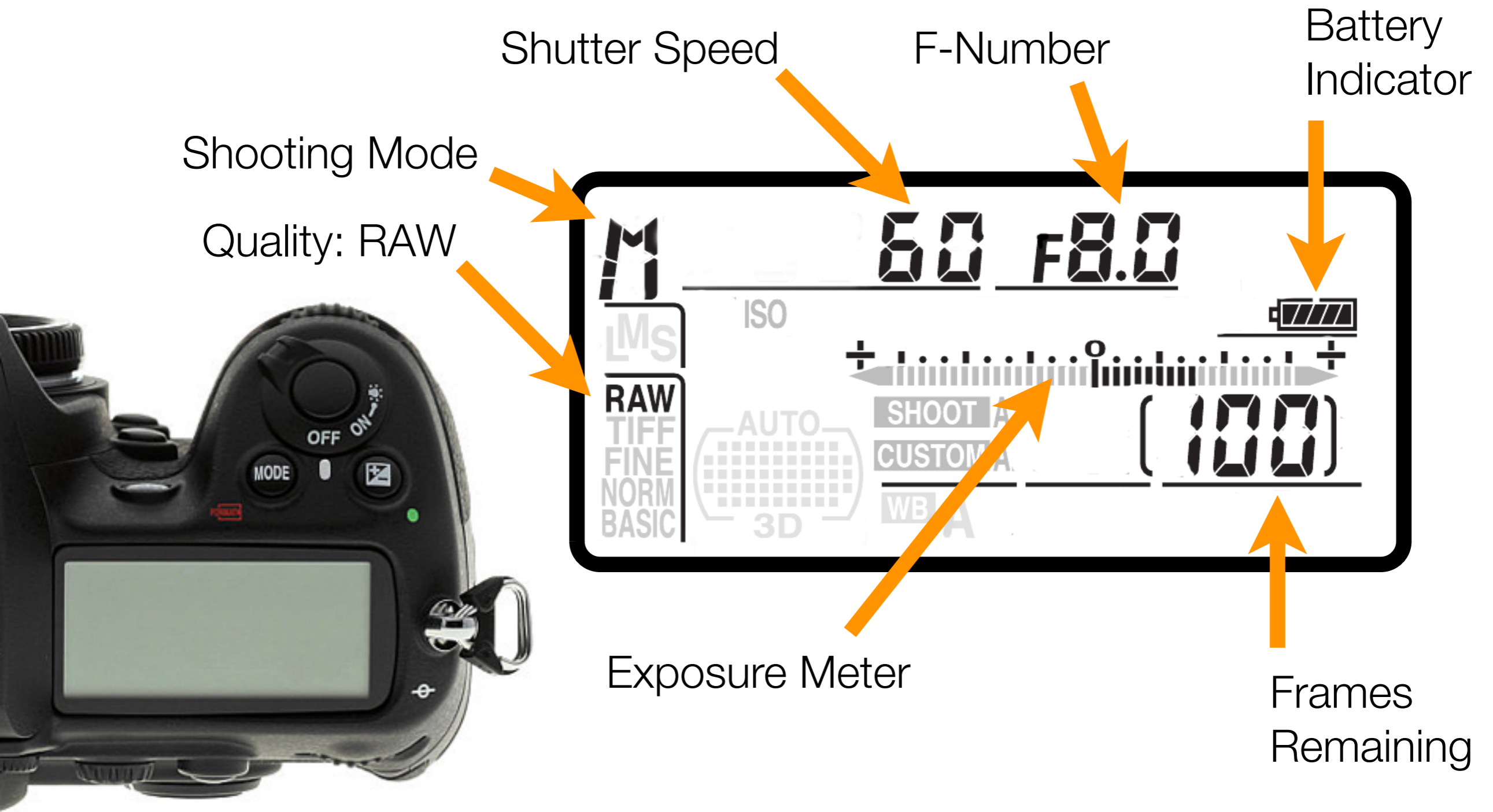

Shutter Speed

F-Number

Battery Indicator

Shooting Mode

Quality: RAW

Exposure Meter

Frames Remaining

Basic dSLR.

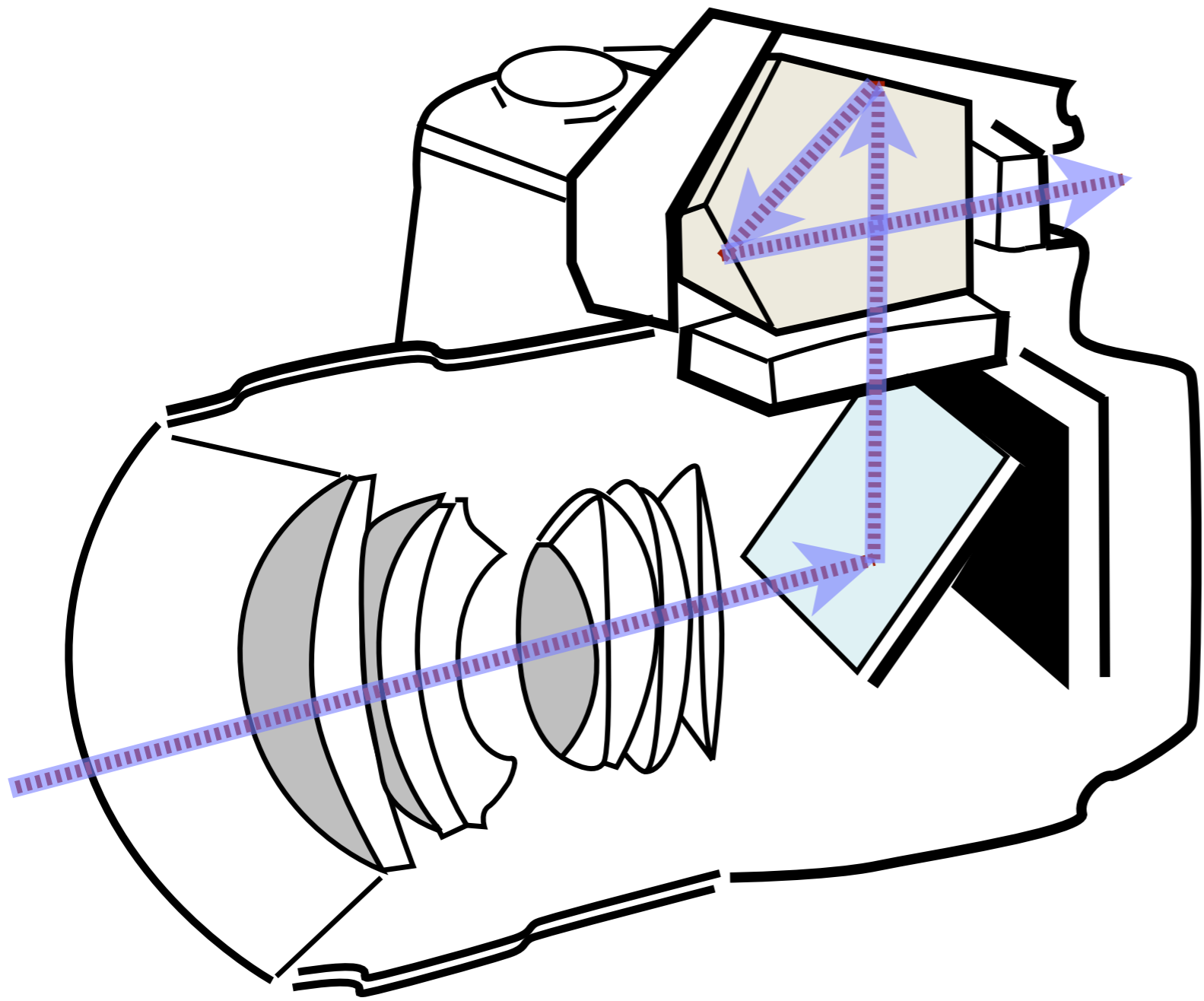

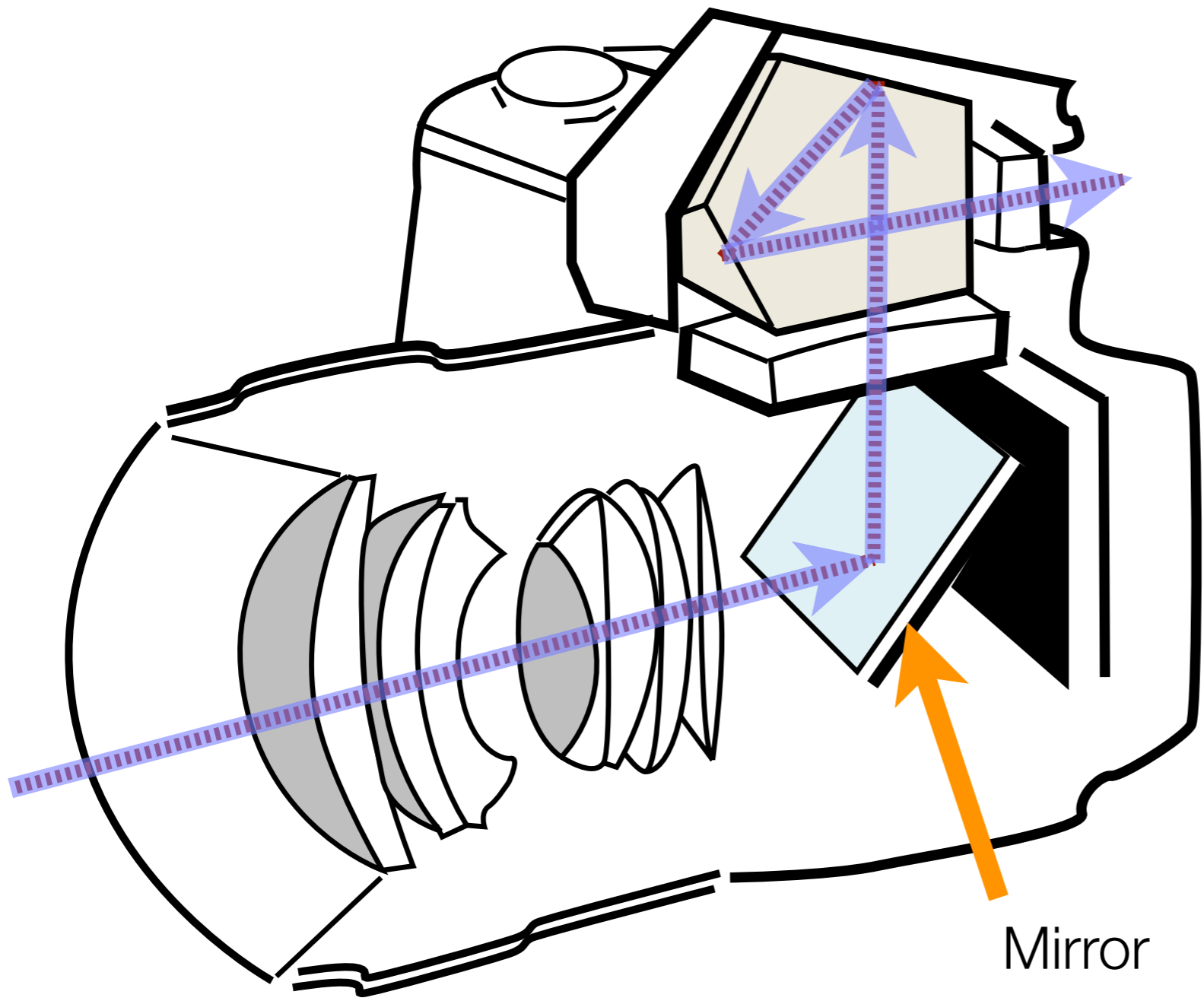

Mirror

